

Yoshida Tools

PENCIL GRINDERS YG-06 Series

*Light weight, Powerful and Durable
Excellent rotation accuracy
Low noise & Low working oscillation*



YG-06-1

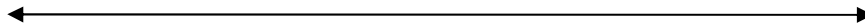

150mm



Specification

Model	Throttle Type	Exhaust Direction	Rotational Frequency	Collet Size	Overall Length	Max Dia	Mass	Max Air Consumption	Air Hose Size	Air Inlet Thread
			min-1			mm				mm
YG-06-1	Roll	Rear	60,000	3	150	16	0.11	0.18	4	1/4-28UNF

Standard Accessory NL-22PFF Coupler Plug, 9Hex, 8Hex Wrench(1each)

Exhaust Hose 35cm (1) , Inlet Hose 135cm (1)

Rubber Protector (1)

Available Option Collet Size: 3.175mm(1/8")

※Specifications are subjects to change without notice.



YOSHIDA MFG.CO.,LTD.

2019.03

Yoshida Tools

Mini Grinder YGT-6

*Light weight, Powerful and Durable
Low noise & Low working oscillation*

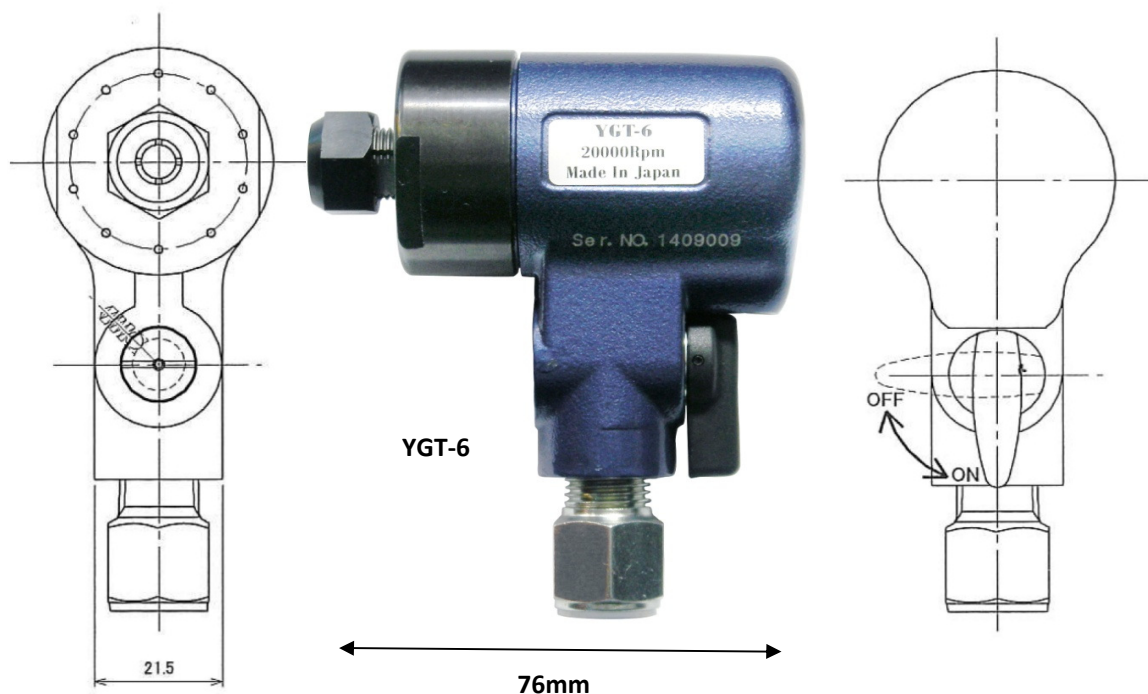

Specification

Model	Throttle Type	Exhaust Direction	Rotational Frequency	Collet Size	Overall Length	Mass	Max Air Consumption	Air Hose Size	Air Inlet Thread
			min-1						
YGT-6	Lever	Front	20,000	6	76	0.4	0.25	9.5	RC1/4

Standard Accessor NL-22PM Coupler Plug, 10mm 17mm Wrench(1each)

※Specifications are subjects to change without notice.



YOSHIDA MFG.CO.,LTD.

2019.03

Yoshida Tools

DIE GRINDERS YG-,YGL-13 Series

Light weight, Powerful and Durable

Excellent rotation accuracy

Low noise & Low working oscillation

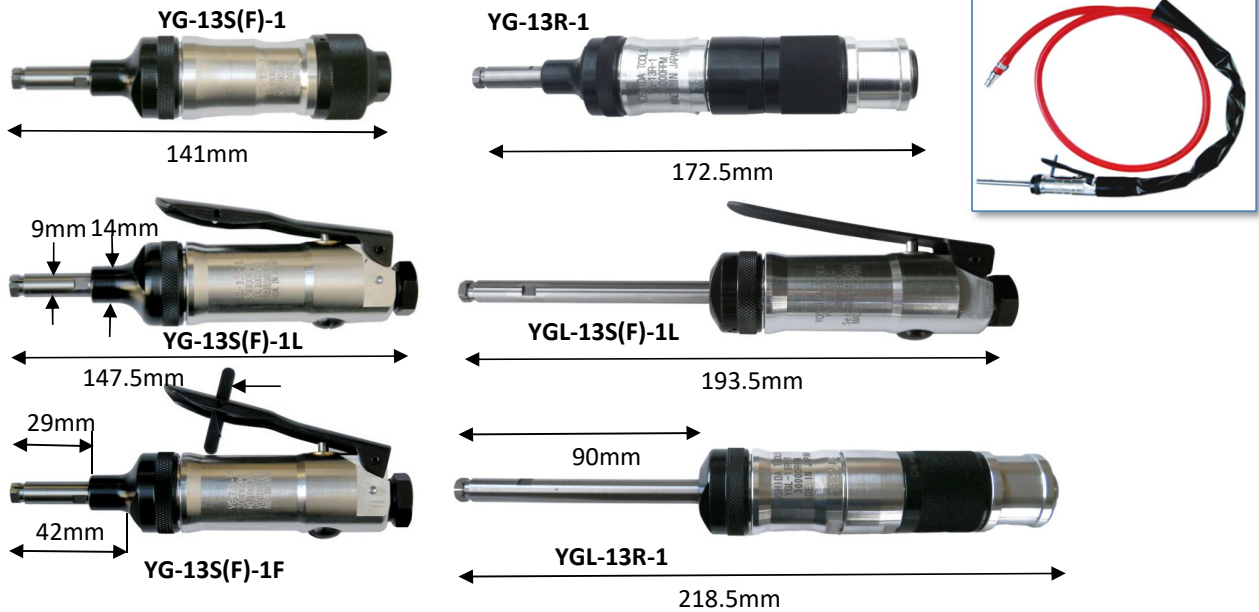

Specification

*Push Lock bar to release the lever

Model	Throttle Type	Exhaust Direction	Rotational Frequency	Collet Size	Overall Length	Max Dia	Mass	Max Air Consumption	Air Hose Size	Air Inlet Thread
			min-1	mm		mm				
YG-13S-1	Roll	Side	30,000	3	141	33	0.31	0.25	6.3	RC1/4
YG-13F-1	Roll	Front	30,000	3	141	33	0.31	0.25	6.3	RC1/4
YG-13S-1L	Lever	Side	30,000	3	147.5	33	0.32	0.25	6.3	RC1/4
YG-13F-1L	Lever	Front	30,000	3	147.5	33	0.32	0.25	6.3	RC1/4
YG-13S-1F	Safety Lever	Side	30,000	3	147.5	33	0.32	0.25	6.3	RC1/4
YG-13F-1F	Safety Lever	Front	30,000	3	147.5	33	0.32	0.25	6.3	RC1/4
YG-13R-1	Roll	Rear	30,000	3	172.5	32.5	0.45	0.25	6.3	RC1/4
YG-13R-1L	Lever	Rear	30,000	3	174.5	32.5	0.35	0.25	6.3	RC1/4
YG-13R-1F	Safety Lever	Rear	30,000	3	174.5	32.5	0.35	0.25	6.3	RC1/4
YGL-13S-1	Roll	Side	30,000	3	186.5	33	0.34	0.25	6.3	RC1/4
YGL-13F-1	Roll	Front	30,000	3	186.5	33	0.34	0.25	6.3	RC1/4
YGL-13S-1L	Lever	Side	30,000	3	193.5	33	0.33	0.25	6.3	RC1/4
YGL-13F-1L	Lever	Front	30,000	3	193.5	33	0.33	0.25	6.3	RC1/4
YGL-13S-1F	Safety Lever	Side	30,000	3	193.5	33	0.35	0.25	6.3	RC1/4
YGL-13F-1F	Safety Lever	Front	30,000	3	193.5	33	0.35	0.25	6.3	RC1/4
YGL-13R-1	Roll	Rear	30,000	3	218.5	32.5	0.35	0.25	6.3	RC1/4
YGL-13R-1L	Lever	Rear	30,000	3	220.5	32.5	0.35	0.25	6.3	RC1/4
YGL-13R-1F	Safety Lever	Rear	30,000	3	220.5	32.5	0.35	0.25	6.3	RC1/4

Standard Accessory: NL-22PM Coupler Plug, 8Hex Wrench(2)

REAR EXHAUST MODELS: 8Hex Wrench(2) EXHAUST HOSE EH030, INLET HOSE IH008

Available Option Collet Size: 3.175mm(1/8")

※Specifications are subjects to change without notice.



YOSHIDA MFG.CO.,LTD.

2019.10

Yoshida Tools

DIE GRINDERS YG,YGL-23 Series

Light weight, Powerful and Durable

Excellent rotation accuracy

Low noise & Low working oscillation

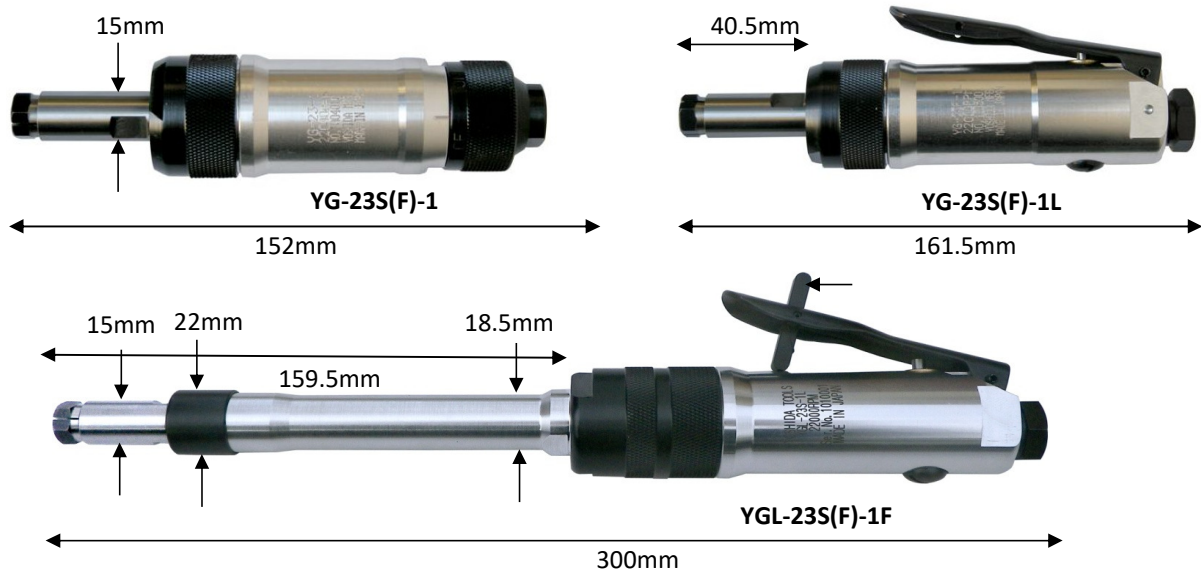

Specification

*Push Lock bar to release the lever

Model	Throttle Type	Exhaust Direction	Rotational Frequency	Collet Size	Overall Length	Max Dia	Mass	Max Air Consumption	Air Hose Size	Air Inlet Thread
			min-1	mm	mm	mm	kg	Nm ³ /min	mm	-
YG-23S-1	Roll	Side	22,000	6	152	37	0.46	0.47	9.5	RC1/4
YG-23F-1	Roll	Front	22,000	6	152	37	0.46	0.47	9.5	RC1/4
YG-23S-1S	Safety Roll	Side	22,000	6	157	38	0.47	0.47	9.5	RC1/4
YG-23F-1S	Safety Roll	Front	22,000	6	157	38	0.47	0.47	9.5	RC1/4
YG-23S-1L	Lever	Side	22,000	6	161.5	37	0.48	0.47	9.5	RC1/4
YG-23F-1L	Lever	Front	22,000	6	161.5	37	0.48	0.47	9.5	RC1/4
YG-23S-1F	Safety Lever	Side	22,000	6	161.5	37	0.48	0.47	9.5	RC1/4
YG-23F-1F	Safety Lever	Front	22,000	6	161.5	37	0.48	0.47	9.5	RC1/4
YGL-23S-1	Roll	Side	22,000	6	290.5	37	0.68	0.47	9.5	RC1/4
YGL-23F-1	Roll	Front	22,000	6	290.5	37	0.68	0.47	9.5	RC1/4
YGL-23S-1S	Safety Roll	Side	22,000	6	295.5	38	0.68	0.47	9.5	RC1/4
YGL-23F-1S	Safety Roll	Front	22,000	6	295.5	38	0.68	0.47	9.5	RC1/4
YGL-23S-1L	Lever	Side	22,000	6	300	37	0.71	0.47	9.5	RC1/4
YGL-23F-1L	Lever	Front	22,000	6	300	37	0.71	0.47	9.5	RC1/4
YGL-23S-1F	Safety Lever	Side	22,000	6	300	37	0.71	0.47	9.5	RC1/4
YGL-23F-1F	Safety Lever	Front	22,000	6	300	37	0.71	0.47	9.5	RC1/4

Standard Accessory: NL-22PM Coupler Plug,13Hex Wrench(2)

Available Option Collet Size: 3mm or 6.35mm(1/4")

※Specifications are subjects to change without notice.



YOSHIDA MFG.CO.,LTD.

2019.07

Yoshida Tools

HIGH POWER DIE GRINDERS YG,YGL-38 Series

Light weight, Powerful and Durable
Excellent rotation accuracy
Low noise & Low working oscillation



Specification

*Push Lock bar to release the lever

Model	Throttle Type	Exhaust Direction	Rotational Frequency min-1	Collet Size mm	Overall Length mm	Max Dia mm	Mass kg	Max Air Consumption Nm ³ /min	Air Hose Size mm	Air Inlet Thread -
YG-38S-1	Roll	Side	22,000	6	162	37	0.5	0.47	9.5	RC1/4
YG-38F-1	Roll	Front	22,000	6	162	37	0.5	0.47	9.5	RC1/4
YG-38S-1S	Safety Roll	Side	22,000	6	167	38	0.51	0.47	9.5	RC1/4
YG-38F-1S	Safety Roll	Front	22,000	6	167	38	0.51	0.47	9.5	RC1/4
YG-38S-1L	Lever	Side	22,000	6	171.5	37	0.52	0.47	9.5	RC1/4
YG-38F-1L	Lever	Front	22,000	6	171.5	37	0.52	0.47	9.5	RC1/4
YG-38S-1F	Safety Lever	Side	22,000	6	171.5	37	0.52	0.47	9.5	RC1/4
YG-38F-1F	Safety Lever	Front	22,000	6	171.5	37	0.52	0.47	9.5	RC1/4
YG-38R-1	Roll	Rear	22,000	6	201.5	37	0.69	0.47	9.5	RC1/4
YG-38R-1L	Lever	Rear	22,000	6	198.5	37	0.57	0.47	9.5	RC1/4
YG-38R-1F	Safety Lever	Rear	22,000	6	198.5	37	0.57	0.47	9.5	RC1/4
YGL-38S-1	Roll	Side	22,000	6	300.5	37	0.71	0.48	9.5	RC1/4
YGL-38F-1	Roll	Front	22,000	6	300.5	37	0.71	0.48	9.5	RC1/4
YGL-38S-1S	Safety Roll	Side	22,000	6	305.5	37	0.71	0.48	9.5	RC1/4
YGL-38F-1S	Safety Roll	Front	22,000	6	305.5	37	0.71	0.48	9.5	RC1/4
YGL-38S-1L	Lever	Side	22,000	6	310	37	0.74	0.48	9.5	RC1/4
YGL-38F-1L	Lever	Front	22,000	6	310	37	0.74	0.48	9.5	RC1/4
YGL-38S-1F	Safety Lever	Side	22,000	6	310	37	0.74	0.48	9.5	RC1/4
YGL-38F-1F	Safety Lever	Front	22,000	6	310	37	0.74	0.48	9.5	RC1/4
YGL-38R-1	Roll	Rear	22,000	6	320	37	0.79	0.48	9.5	RC1/4
YGL-38R-1L	Lever	Rear	22,000	6	337	37	0.79	0.48	9.5	RC1/4
YGL-38R-1F	Safety Lever	Rear	22,000	6	337	37	0.79	0.48	9.5	RC1/4

Standard Accessory: NL-22PM Coupler Plug,13Hex Wrench(2), FOR YG-38R:IH008 Exhaust Hose 1.5m,EH030 Inlet Hose0.5m

Available Option Collet Size: 3mm or 6.35mm(1/4")

※Specifications are subjects to change without notice.



YOSHIDA MFG.CO.,LTD.

2019.07

Yoshida Tools

STRAIGHT GRINDERS YG-3H,3HA Series

Light weight, Powerful and Durable
Excellent rotation accuracy
Low noise & Low working oscillation

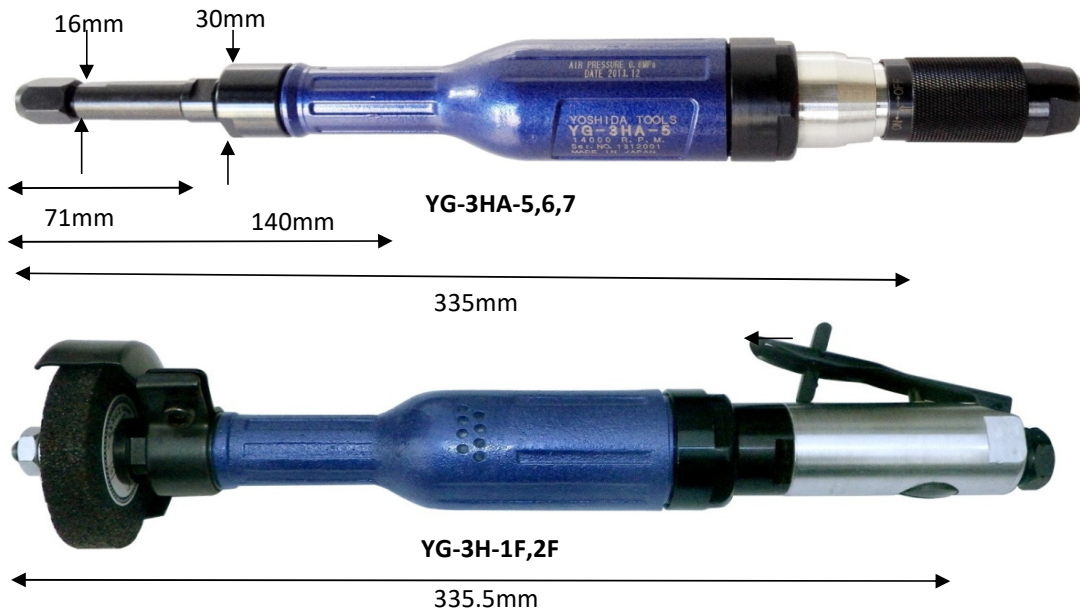

Specification

For Mounted Wheel *Push Lock bar to release the lever

Model	Throttle Type	Exhaust Direction	Rotational Frequency	Collet Size	Overall Length	Wheel Size DxT	Mass	Max Air Consumption	Air Hose Size	Air Inlet Thread
			min-1	mm	mm	mm				
YG-3HA-5	Roll	Side	14,000	6	335	45x13	1.17	0.68	9.5	RC3/8
YG-3HA-5F	Safety Lever	Side	14,000	6	364	45x13	1.29	0.68	9.5	RC3/8
YG-3HA-7	Roll	Side	18,000	6	335	45x13	1.17	0.68	9.5	RC3/8
YG-3HA-7F	Safety Lever	Side	18,000	6	364	45x13	1.29	0.68	9.5	RC3/8

For Wire Brush

Model	Throttle Type	Exhaust Direction	Rotational Frequency	Collet Size	Overall Length	Brush Size DxL	Mass	Max Air Consumption	Air Hose Size	Air Inlet Thread
			min-1	mm	mm	mm				
YG-3HA-6	Roll	Side	12,000	6	335	15x50	1.17	0.68	9.5	RC3/8
YG-3HA-6F	Safety Lever	Side	12,000	6	364	15x50	1.29	0.68	9.5	RC3/8

Standard Accessory: NL-23PM Coupler Plug,14Hex Wrench

Available Option Collet Size: 6.35mm(1/4")

For Grinding Wheel

Model	Throttle Type	Exhaust Direction	Rotational Frequency	Weel Size	Overall Length	Spindle Thread	Mass w/Guard	Max Air Consumption	Air Hose Size	Air Inlet Thread
			min-1	mm	mm	in				
YG-3H-1	Roll	Side	14,600	65x13x9.53	307	W3/8-16	1.3	0.68	9.5	RC3/8
YG-3H-2	Roll	Side	12,700	75x13x9.53	307	W3/8-16	1.3	0.68	9.5	RC3/8
YG-3H-1F	Safety Lever	Side	14,600	65x13x9.53	335.5	W3/8-16	1.44	0.68	9.5	RC3/8
YG-3H-2F	Safety Lever	Side	12,700	75x13x9.53	335.5	W3/8-16	1.44	0.68	9.5	RC3/8

Standard Accessory: NL-23PM Coupler Plug,21Hex Wrench, 5Hex Whench

※Specifications are subjects to change without notice.



YOSHIDA MFG.CO.,LTD.

2019.03

Yoshida Tools

STRAIGHT GRINDERS YGL-3H,3HA,3HB Series

*Light weight, Powerful and Durable
Excellent rotation accuracy
Low noise & Low working oscillation*

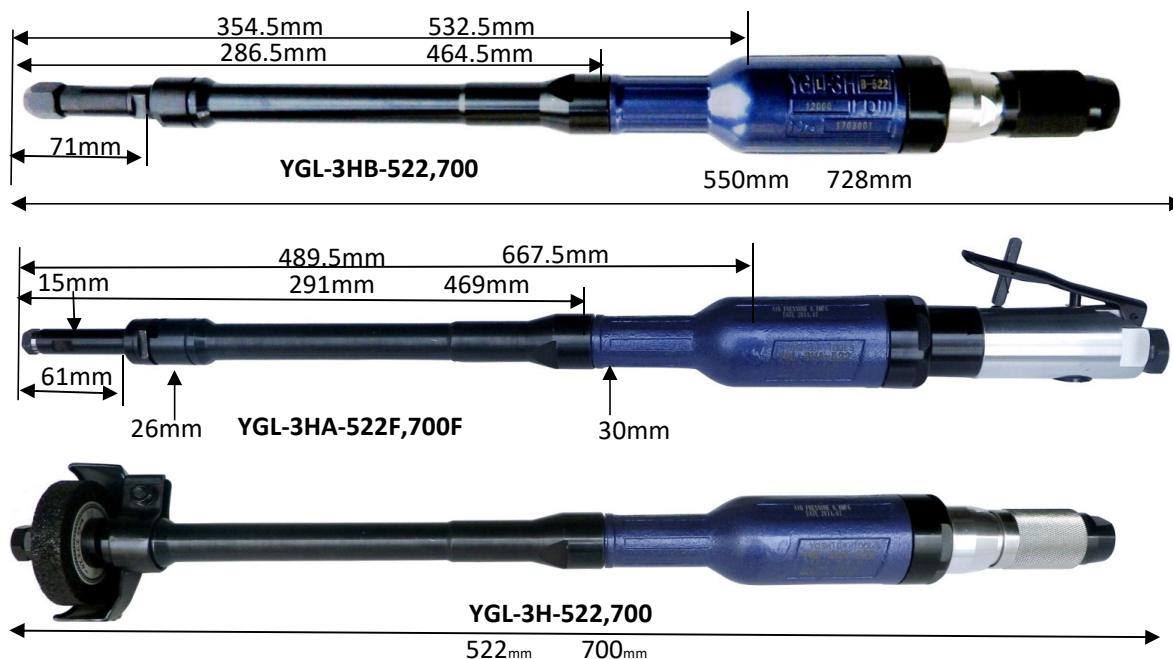

Specification

For Mounted Wheel

Model	Throttle Type	Exhaust Direction	Rotational Frequency	Collet Size	Overall Length	Wheel Size	Mass	Max Air Consumption	Air Hose Size	Air Inlet Thread
			min-1	mm	mm	DxT				
YGL-3HA-522	Roll	Side	12,000	6	554.5	45x13	1.70	0.68	9.5	RC3/8
YGL-3HA-700	Roll	Side	12,000	6	732.5	45x13	2.04	0.68	9.5	RC3/8
YGL-3HB-522	Roll	Side	12,000	6	550	45x13	1.70	0.68	9.5	RC3/8
YGL-3HB-700	Roll	Side	12,000	6	728	45x13	2.04	0.68	9.5	RC3/8
YGL-3HA-522F	Safety Lever	Side	12,000	6	582.5	45x13	1.84	0.68	9.5	RC3/8
YGL-3HA-700F	Safety Lever	Side	12,000	6	761	45x13	2.18	0.68	9.5	RC3/8
YGL-3HB-522F	Safety Lever	Side	12,000	6	578.5	45x13	1.84	0.68	9.5	RC3/8
YGL-3HB-700F	Safety Lever	Side	12,000	6	756.5	45x13	2.18	0.68	9.5	RC3/8

Standard Accessory: NL-23PM, YGL-3HA SPA013 13HEX Wrench(2) YGL-3HB SPA014 14Hex Wrench(1)

Available Option Collet Size: 3mm or 6.35mm(1/4")

For Flat Grinding Wheel

Model	Throttle Type	Exhaust Direction	Rotational Frequency	Wheel Size	Overall Length	Spindle Thread	Mass w/Guard	Max Air Consumption	Air Hose Size	Air Inlet Thread
			min-1	mm	mm	in				
YGL-3H-522	Roll	Side	12,000	55x13x9.53	522	W3/8-16	1.76	0.68	9.5	RC3/8
YGL-3H-700	Roll	Side	12,000	55x13x9.53	700	W3/8-16	2.10	0.68	9.5	RC3/8
YGL-3H-522F	Safety Lever	Side	12,000	55x13x9.53	550.5	W3/8-16	1.90	0.68	9.5	RC3/8
YGL-3H-700F	Safety Lever	Side	12,000	55x13x9.53	728.5	W3/8-16	2.20	0.68	9.5	RC3/8

Standard Accessory: NL-23PM Coupler Plug, 21Hex Wrench, 5Hex Wrench

※Specifications are subjects to change without notice.



YOSHIDA MFG.CO.,LTD.

2019.10

Yoshida Tools

STRAIGHT GRINDERS YG,YGL-4H Series

*Light weight, Powerful and Durable
Low noise & Low working oscillation*

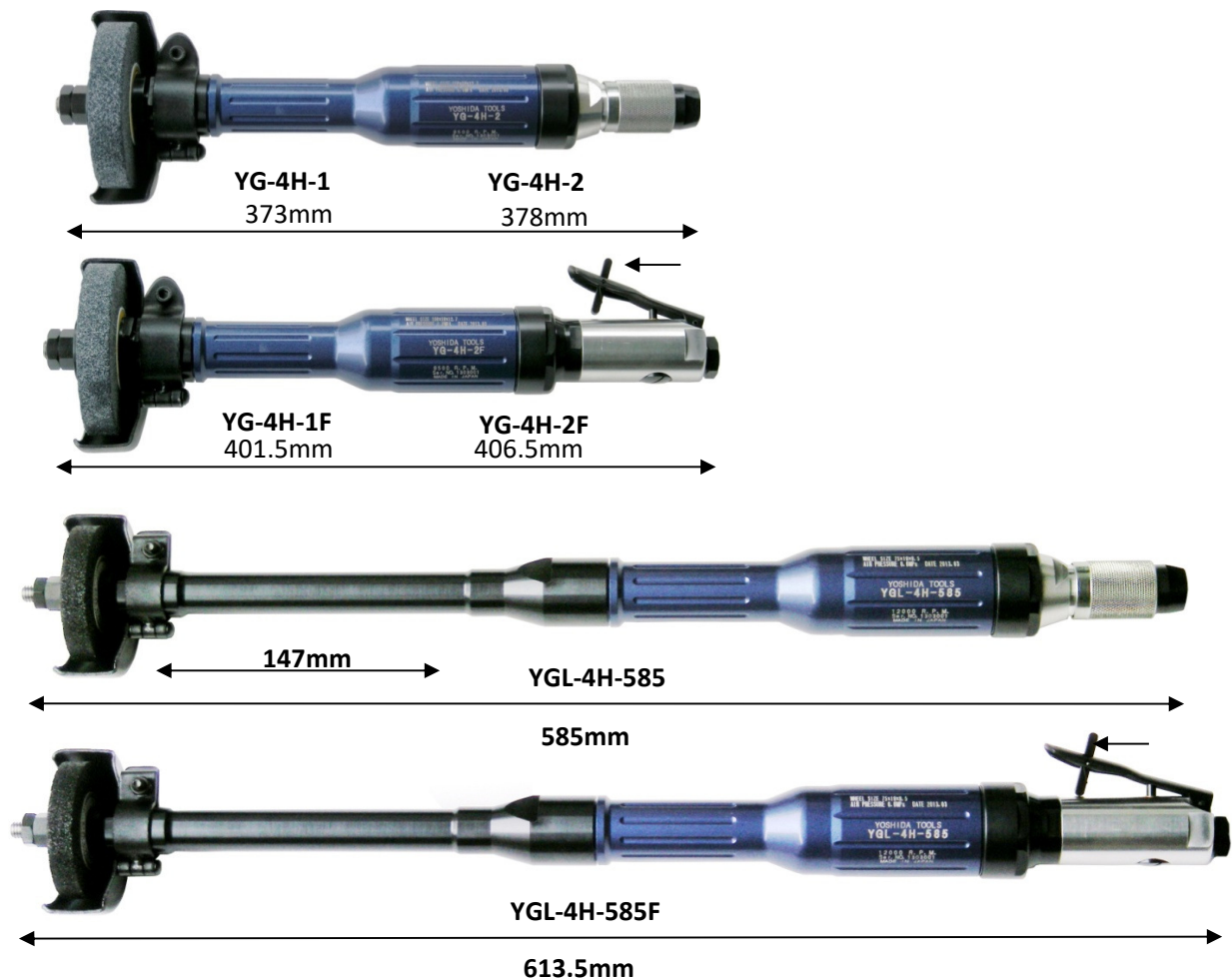

Specification

*Push Lock bar to release the lever

Model	Throttle Type	Exhaust Direction	Rotational Frequency	Weel Size	Overall Length	Spindle Thread	Mass w/Guard	Max Air Consumption	Air Hose Size	Air Inlet Thread
			min-1	mm	mm	in	kg	Nm3/min	mm	-
YG-4H-1	Roll	Side	9,500	100x19x9.53	373	W3/8-16	2.05	0.75	12.7	RC3/8
YG-4H-2	Roll	Side	9,500	100x19x12.7	378	W1/2-12	2.09	0.75	12.7	RC3/8
YG-4H-1F	Safty Lever	Side	9,500	100x19x9.53	401.5	W3/8-16	2.15	0.75	12.7	RC3/8
YG-4H-2F	Safty Lever	Side	9,500	100x19x12.7	406.5	W1/2-12	2.19	0.75	12.7	RC3/8

Standard Accessory: NL-23PM Coupler Plug,32Hex Wrench, 5Hex Whench

Model	Throttle Type	Exhaust Direction	Rotational Frequency	Weel Size	Overall Length	Spindle Thread	Mass w/Guard	Max Air Consumption	Air Hose Size	Air Inlet Thread
			min-1	mm	mm	in	kg	Nm3/min	mm	-
YGL-4H-585	Roll	Side	12,000	75x19x9.53	585	W3/8-16	2.5	0.75	12.7	RC3/8
YGL-4H-585F	Safty Lever	Side	12,000	75x19x9.53	613.5	W3/8-16	2.6	0.75	12.7	RC3/8

Standard Accessory: NL-23PM Coupler Plug,21Hex Wrench, 5Hex Whench



Yoshida Tools

STRAIGHT GRINDERS YG, YGL-5H Series

*Light weight, Powerful and Durable
Low noise & Low working oscillation*

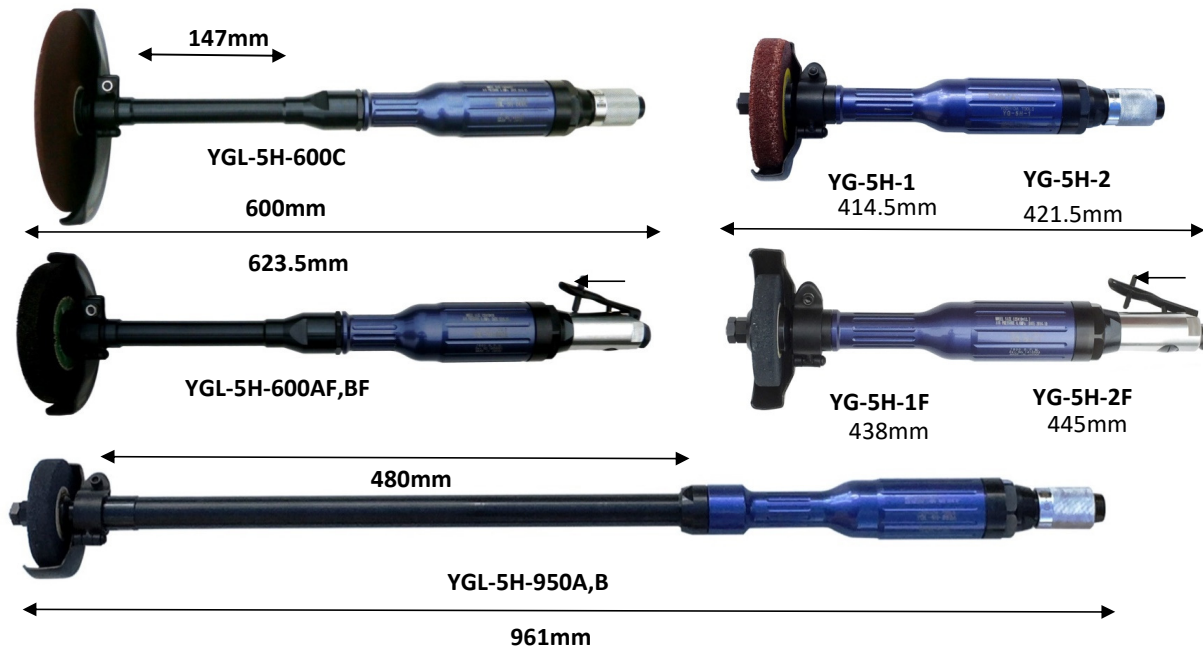

Specification

*Push Lock bar to release the lever

For Flat Grinding Wheel

Model	Throttle Type	Exhaust Direction	Rotational Frequency	Wheel Size	Overall Length	Spindle Thread	Mass w/Guard	Max Air Consumption	Air Hose Size	Air Inlet Thread
			min-1	mm	mm	in	kg	Nm3/min	mm	-
YG-5H-1	Roll	Side	7,600	125x19x12.7	414.5	W1/2-12	2.95	1.10	12.7	RC3/8
YG-5H-2	Roll	Side	7,600	125x19x15.8	421.5	5/8-11UNC	2.98	1.10	12.7	RC3/8
YG-5H-1F	Safety Lever	Side	7,600	125x19x12.7	438	W1/2-12	3.10	1.10	12.7	RC3/8
YG-5H-2F	Safety Lever	Side	7,600	125x19x15.8	445	5/8-11UNC	3.13	1.10	12.7	RC3/8

Standard Accessory: NL-23PM Plug, 32Hex Wrench, 5Hex Whench

Model	Throttle Type	Exhaust Direction	Rotational Frequency	Wheel Size	Overall Length	Spindle Thread	Mass w/Guard	Max Air Consumption	Air Hose Size	Air Inlet Thread
			min-1	mm	mm	in	kg	Nm3/min	mm	-
YGL-5H-600A	Roll	Side	12,000	75x19x9.5	600	W3/8-16	3.30	1.10	12.7	RC3/8
YGL-5H-600B	Roll	Side	9,000	100x19x12.7	600	W3/8-16	3.30	1.10	12.7	RC3/8
YGL-5H-600E	Roll	Side	7,600	125x19x16	600	W3/8-16	3.30	1.10	12.7	RC3/8
YGL-5H-600AF	Lock Lever	Side	12,000	75x19x9.5	623.5	W3/8-16	3.40	1.10	12.7	RC3/8
YGL-5H-600BF	Lock Lever	Side	9,000	100x19x12.7	623.5	W3/8-16	3.40	1.10	12.7	RC3/8
YGL-5H-600EF	Lock Lever	Side	7,600	125x19x16	623.5	W3/8-16	3.40	1.10	12.7	RC3/8
YGL-5H-950A	Roll	Side	12,000	75x19x12.7	961	W1/2-12	5.33	1.10	12.7	RC3/8
YGL-5H-950B	Roll	Side	9,000	100x19x12.7	961	W1/2-12	5.33	1.10	12.7	RC3/8
YGL-5H-950AF	Lock Lever	Side	12,000	75x19x12.7	984	W1/2-12	5.48	1.10	12.7	RC3/8
YGL-5H-950BF	Lock Lever	Side	9,000	100x19x12.7	984	W1/2-12	5.48	1.10	12.7	RC3/8

Standard Accessory: NL-23PM Plug, 26Hex Spanner, 5Hex Whench

For Offset Wheel

YGL-5H-600C	Roll	Side	7,600	180x6x22	600	W3/8-16	3.30	1.10	12.7	RC3/8
YGL-5H-600CF	Lock Lever	Side	7,600	180x6x22	623.5	W3/8-16	3.40	1.10	12.7	RC3/8

For Inner Grinding (without Wheel Cover)

YGL-5H-600AN	Roll	Side	12,000	75x19x9.5	600	W3/8-16	3.20	1.10	12.7	RC3/8
YGL-5H-600BN	Roll	Side	9,000	100x19x12.7	600	W3/8-16	3.20	1.10	12.7	RC3/8

Standard Accessory: NL-23PM Plug, 26Hex Spanner, 5Hex Whench



YOSHIDA MFG.CO.,LTD.

2019.03

※Specifications are subjects to change without notice.

Yoshida Tools

ANGLE GRINDERS YA-2C Series

*Light weight and compact body for easy handling
Endurable for long-term use by strong gear system
Suitable for deburring and finishing work
Excellent rotation accuracy*

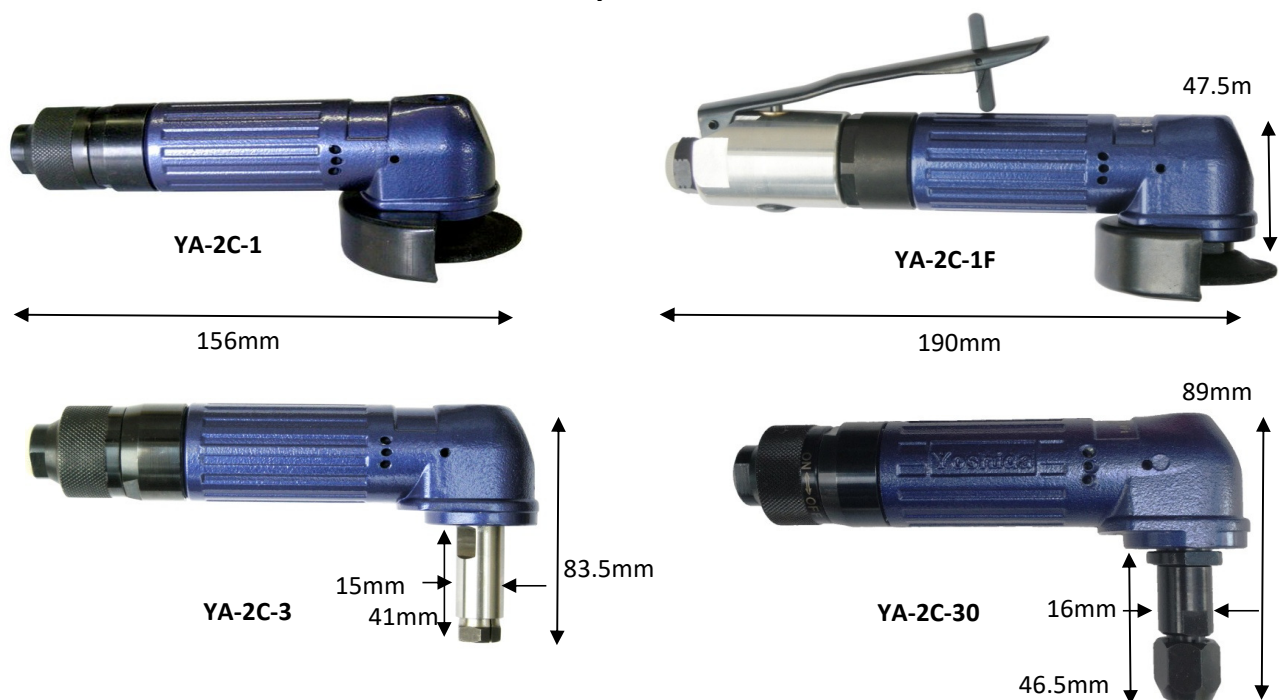

Specification

Model	Throttle Type	Rotational Frequency	Wheel Size	Peripheral Speed	Overall Length	Head Height	Mass w/Guard	Max Air Consumption	Air Hose Size	Air Inlet Thread
		min-1	mm	m/min	mm	mm				
YA-2C-1	Roll	15,000	50x4x9.5	4,300	156	47.5	0.645	0.4	9.5	RC1/4
YA-2C-1F	Safety Lever	15,000	50x4x9.5	4,300	188	47.5	0.7	0.4	9.5	RC1/4

Standard Accessories....19Hex Wrench, 5Hex Pin Wrench, 3Hex Pin Wrench,Coupler Plug NL-22PM

Model	Throttle Type	Rotational Frequency	collet Size	Peripheral Speed	Overall Length	Head Height	Mass	Max Air Consumption	Air Hose Size	Air Inlet Thread
		min-1	mm	m/min	mm	mm				
YA-2C-3	Roll	15,000	6	2,000	156	83.5	0.6	0.40	9.5	RC1/4
YA-2C-3F	Safety Lever	15,000	6	2,000	190	83.5	0.7	0.40	9.5	RC1/4
YA-2C-30	Roll	15,000	6	2,000	156	89	0.64	0.40	9.5	RC1/4
YA-2C-30F	Safety Lever	15,000	6	2,000	190	89	0.7	0.40	9.5	RC1/4

Standard Accessories....13Hex Wrench(2), Coupler Plug NL-22PM

Available Option Collet Size : 3mm or 6.35mm (1/4")

Yoshida Tools

ANGLE GRINDERS YA-3C 3CH Series

Compact, Light weight, Powerful and Durable

Ideal for middle class grinding work, such as finishing welded surface, grinding off padding of casting etc.

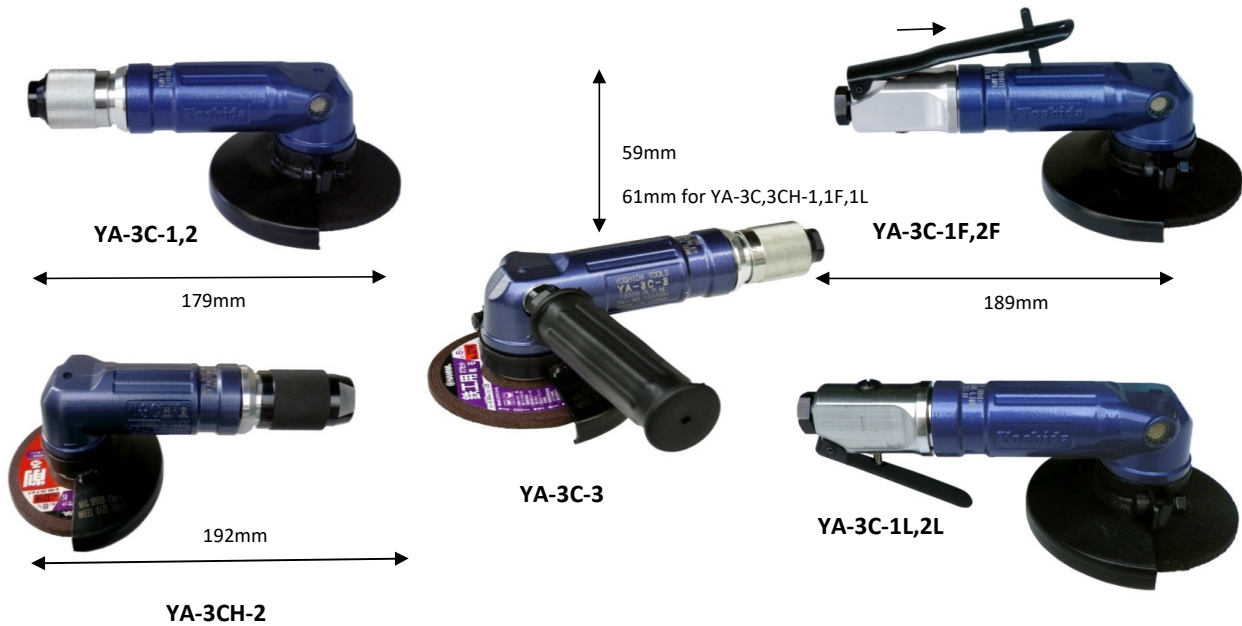

Specification

*Push Lock bar to release the lever

Model	Throttle Type	Rotational Frequency	Wheel Size	Peripheral Speed	Overall Length	Head Height	Mass w/Guard	Max Air Consumption	Air Hose Size	Air Inlet Thread
		min-1	mm	m/min	mm	mm	kg	Nm3/min	mm	-
YA-3C-1	Roll	13,500	75x4x9.5	4,300	179	61.0	0.92	0.40	9.5	RC1/4
YA-3C-1L	Lever	13,500	75x4x9.5	4,300	189	61.0	0.95	0.40	9.5	RC1/4
YA-3C-1F	Safety Lever	13,500	75x4x9.5	4,300	189	61.0	0.95	0.40	9.5	RC1/4
YA-3C-2	Roll	13,000	100x6x15(15.8)	4,300	179	59.0	0.97	0.40	9.5	RC1/4
YA-3C-2L	Lever	13,000	100x6x15(15.8)	4,300	189	59.0	1.00	0.40	9.5	RC1/4
YA-3C-2F	Safety Lever	13,000	100x6x15(15.8)	4,300	189	59.0	1.00	0.40	9.5	RC1/4
YA-3C-3	Roll	13,000	100x6x15(15.8)	4,300	179	59.0	1.09	0.40	9.5	RC1/4
YA-3C-3L	Lever	13,000	100x6x15(15.8)	4,300	189	59.0	1.12	0.40	9.5	RC1/4
YA-3C-3F	Safety Lever	13,000	100x6x15(15.8)	4,300	189	59.0	1.12	0.40	9.5	RC1/4

Standard Accessories.....32Hex Wrench, 6Hex Pin Wrench (Not for YA-3C-1,1L,1F),5Hex Pin Wrench, Coupler Plug NL-22PM

HEAVY DUTY MODEL										
YA-3CH-1	Roll	13,500	75x4x9.5	4,300	192	61.0	1.05	0.62	9.5	RC3/8
YA-3CH-1L	Lever	13,500	75x4x9.5	4,300	199	61.0	0.99	0.62	9.5	RC3/8
YA-3CH-1F	Safety Lever	13,500	75x4x9.5	4,300	199	61.0	0.99	0.62	9.5	RC3/8
YA-3CH-2	Roll	13,500	100x6x15	4,300	192	59.0	1.10	0.62	9.5	RC3/8
YA-3CH-2L	Lever	13,500	100x6x15	4,300	199	59.0	1.04	0.62	9.5	RC3/8
YA-3CH-2F	Safety Lever	13,500	100x6x15	4,300	199	59.0	1.04	0.62	9.5	RC3/8
YA-3CH-3	Roll	13,500	100x6x15	4,300	192	59.0	1.20	0.62	9.5	RC3/8
YA-3CH-3L	Lever	13,500	100x6x15	4,300	199	59.0	1.22	0.62	9.5	RC3/8
YA-3CH-3F	Safety Lever	13,500	100x6x15	4,300	199	59.0	1.25	0.62	9.5	RC3/8

Standard Accessories.....32Hex Wrench, 6Hex Pin Wrench, 5Hex Pin Wrench, Coupler Plug NL-23PM

Cation

Use only Offset Grinding Wheel 75,100mm listed on above specification meeting rotational frequency
Ask us for other grinding wheel or cutter use

※Specifications are subjects to change without notice.



YOSHIDA MFG.CO.,LTD.

2019.05

Yoshida Tools

ANGLE GRINDERS YA-4C Series

Light weight, Powerful and Durable

Ideal for heavy grinding work, such as shipbuilding, bridge construction



YA-4C-1
YA-4CW-1,2,6

217mm



YA-4C,4CW-3
NO DEAD HANDLE ATTACHED



YA-4C-1F
YA-4CW-1F,2F,6F

LOCK LEVER

77mm

*Push Lock bar to release the lever

246mm



YA-4CP,4CWP
FRONT EXHAUST



YA-4CS,4CWS
SIDE EXHAUST

Specification

Model	Throttle Type	Rotational Frequency	Wheel Size	Peripheral Speed	Overall Length	Head Height	Mass w/Guard	Max Air Consumption	Air Hose Size	Air Inlet Thread
		min-1	mm	m/min	mm	mm	kg	Nm ³ /min	mm	-
YA-4C-1	Roll	13,500	100x6x15	4,300	217	77	1.78	0.68	9.5	RC3/8
YA-4CW-1	Roll	11,000	100x6x15	4,300	217	77	1.78	0.68	9.5	RC3/8
YA-4C-1F	Safety Lever	13,500	100x6x15	4,300	246	77	1.91	0.68	9.5	RC3/8
YA-4CW-1F	Safety Lever	11,000	100x6x15	4,300	246	77	1.91	0.68	9.5	RC3/8
YA-4C-3	Roll	13,500	100x6x15	4,300	217	77	1.63	0.68	9.5	RC3/8
YA-4CW-3	Roll	11,000	100x6x15	4,300	217	77	1.63	0.68	9.5	RC3/8
YA-4C-3F	Safety Lever	13,500	100x6x15	4,300	246	77	1.76	0.68	9.5	RC3/8
YA-4CW-3F	Safety Lever	11,000	100x6x15	4,300	246	77	1.76	0.68	9.5	RC3/8
YA-4CW-2	Roll	10,900	125x6x22	4,300	217	77	1.88	0.68	9.5	RC3/8
YA-4CW-2F	Safety Lever	10,900	125x6x22	4,300	246	77	2.01	0.68	9.5	RC3/8
YA-4CW-6	Roll	7,600	180x6x22	4,300	217	77	2.10	0.68	9.5	RC3/8
YA-4CW-6F	Safety Lever	7,600	180x6x22	4,300	246	77	2.23	0.68	9.5	RC3/8
FRONT EXHAUST(4CP,4CWP) SIDE EXHAUST(4CS,4CWS)										
YA-4CP(S)-1	Roll	13,500	100x6x15	4,300	217	77	1.78	0.68	9.5	RC3/8
YA-4CWP(S)-1	Roll	11,000	100x6x15	4,300	217	77	1.78	0.68	9.5	RC3/8
YA-4CP(S)-1F	Safety Lever	13,500	100x6x15	4,300	246	77	1.91	0.68	9.5	RC3/8
YA-4CWP(S)-1F	Safety Lever	11,000	100x6x15	4,300	246	77	1.91	0.68	9.5	RC3/8
YA-4CP(S)-3	Roll	13,500	100x6x15	4,300	217	77	1.63	0.68	9.5	RC3/8
YA-4CWP(S)-3	Roll	11,000	100x6x15	4,300	217	77	1.63	0.68	9.5	RC3/8
YA-4CP(S)-3F	Safety Lever	13,500	100x6x15	4,300	246	77	1.76	0.68	9.5	RC3/8
YA-4CWP(S)-3F	Safety Lever	11,000	100x6x15	4,300	246	77	1.76	0.68	9.5	RC3/8
YA-4CWP(S)-2	Roll	10,900	125x6x22	4,300	217	77	1.88	0.68	9.5	RC3/8
YA-4CWP(S)-2F	Safety Lever	10,900	125x6x22	4,300	246	77	2.01	0.68	9.5	RC3/8
YA-4CWP(S)-6	Roll	7,600	180x6x22	4,300	217	77	2.10	0.68	9.5	RC3/8
YA-4CWP(S)-6F	Safety Lever	7,600	180x6x22	4,300	246	77	2.23	0.68	9.5	RC3/8

Standard Accessories....32Hex Wrench,6Hex Pin Wrench,5Hex Pin Wrench, Coupler Plug NL-23PM

Use only Offset Grinding Wheel 100,125,180mm listed on

above specification meeting rotational frequency

Ask us for other grinding wheel or cutter use

※Specifications are subjects to change without notice.



YOSHIDA MFG.CO.,LTD.

2020.02

Yoshida Tools

ANGLE GRINDERS YA-6C Series

Light weight, Powerful and Durable

Ideal for heavy grinding work, such as shipbuilding, bridge construction



252mm



252mm



89mm

273mm

*Push Lock bar to release the lever



89mm

276mm

Specification

Model	Handle Type	Exhaust Direction	Rotational Frequency	Wheel Size	Peripheral Speed	Overall Length	Head Height	Mass w/Guard	Max Air Consumption	Air Hose Size	Air Inlet Thread
			m-1	mm	m/min	mm	mm	kg	Nm3/min	mm	-
YA-6C-1	Roll	Rotational	7,600	180x6x22	4,300	252	89	2.8	1.1	12.7	RC3/8
YA-6C-1F	Safety Lever	Rotational	7,600	180x6x22	4,300	276	89	2.9	1.1	12.7	RC3/8
YA-6C-2	Roll	Rotational	9,100	150x6x22	4,300	252	89	2.75	1.1	12.7	RC3/8
YA-6C-2F	Safety Lever	Rotational	9,100	150x6x22	4,300	276	89	2.85	1.1	12.7	RC3/8
HEAVY DUTY MODEL											
YA-6CHP-1	Roll	Front	7,600	180x6x22	4,300	252	89	2.72	1.1	12.7	RC3/8
YA-6CHP-1F	Safety Lever	Front	7,600	180x6x22	4,300	276	89	2.82	1.1	12.7	RC3/8
YA-6CHP-10	Roll	Front	8,400	180x6x22.2	4,800	252	89	2.72	1.1	12.7	RC3/8
YA-6CHP-10F	Safety Lever	Front	8,400	180x6x22.2	4,800	276	89	2.82	1.1	12.7	RC3/8
YA-6CHP-2	Roll	Front	9,100	150x6x22	4,300	252	89	2.72	1.1	12.7	RC3/8
YA-6CHP-2F	Safety Lever	Front	9,100	150x6x22	4,300	276	89	2.82	1.1	12.7	RC3/8
YA-6CHS-1	Roll	Side	7,600	180x6x22	4,300	252	89	2.72	1.1	12.7	RC3/8
YA-6CHS-1F	Safety Lever	Side	7,600	180x6x22	4,300	276	89	2.82	1.1	12.7	RC3/8
YA-6CHS-10	Roll	Side	8,400	180x6x22.2	4,800	252	89	2.72	1.1	12.7	RC3/8
YA-6CHS-10F	Safety Lever	Side	8,400	180x6x22.2	4,800	276	89	2.82	1.1	12.7	RC3/8
YA-6CHS-2	Roll	Side	9,100	150x6x22	4,300	252	89	2.72	1.1	12.7	RC3/8
YA-6CHS-2F	Safety Lever	Side	9,100	150x6x22	4,300	276	89	2.82	1.1	12.7	RC3/8
YA-6CH IS MORE POWERFUL THAN YA-6C AND YA-6CW IS STRONGEST MODEL											
YA-6CWP-1	Roll	Front	7,600	180x6x22	4,300	273	89	2.94	1.11	12.7	RC1/2
YA-6CWP-1F	Safety Lever	Front	7,600	180x6x22	4,300	297	89	3.04	1.11	12.7	RC1/2
YA-6CWP-10	Roll	Front	8,400	180x6x22.2	4,800	273	89	2.94	1.11	12.7	RC1/2
YA-6CWP-10F	Safety Lever	Front	8,400	180x6x22.2	4,800	297	89	3.04	1.11	12.7	RC1/2
YA-6CWS-1	Roll	Side	7,600	180x6x22	4,300	273	89	2.94	1.11	12.7	RC1/2
YA-6CWS-1F	Safety Lever	Side	7,600	180x6x22	4,300	297	89	3.04	1.11	12.7	RC1/2
YA-6CWS-10	Roll	Side	8,400	180x6x22.2	4,800	273	89	2.94	1.11	12.7	RC1/2
YA-6CWS-10F	Safety Lever	Side	8,400	180x6x22.2	4,800	297	89	3.04	1.11	12.7	RC1/2

Standard Accessories.....26Hex Wrench, .10Hex Wrench,8Hex Pin Wrench, Coupler Plug NL-23PM, NL-24PM (YA-6CW)

Caution

Use 150mm, 180mm Off-Set Grinding Wheel only
 Contact our staff for using Cutting Wheel or Cutter as you need to use additional part.
 Don't use 4300m/min. Peripheral Speed Grinding Wheel for YA-6CH and YA-6CW models
 Use 1/2 Hose for YA-6CW models to keep the power.

※Specifications are subjects to change without notice.



YOSHIDA MFG.CO.,LTD.
2019.05

Yoshida Tools

ANGLE GRINDERS YA-3K,5K Series

Light weight, Powerful and Durable
Ideal for heavy grinding, sanding and brushing work
such as shipbuilding, bridge construction

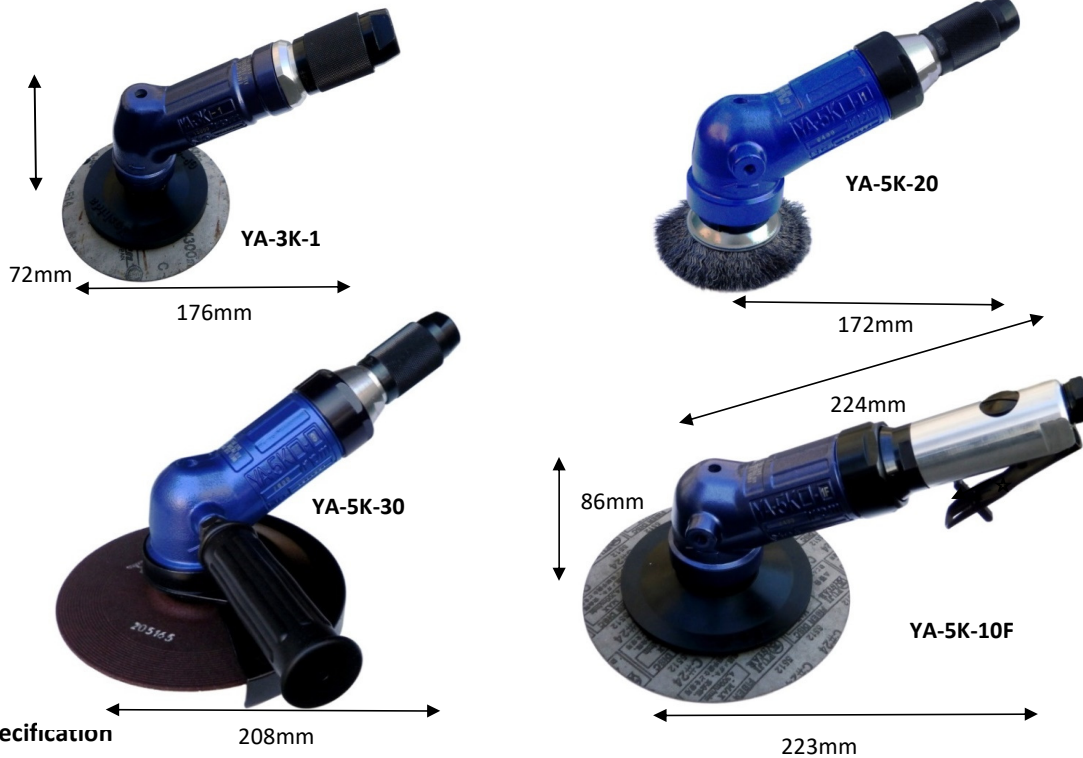

Specification

For Sanding Paper

Model	Throttle Type	Rotational Frequency	Sanding Paper Size	Overall Length	Head Height	Mass w/Pad	Max Air Consumption	Air Hose Size	Air Inlet Thread
		min-1	mm	mm	mm	kg	Nm ³ /min	mm	-
YA-3K-1	Roll	13,000	100x16	176	72	0.94	0.40	9.5	RC3/8
YA-3K-1L	Lever	13,000	100x16	177	72	1.00	0.40	9.5	RC3/8
YA-3K-1F	Safety Lever	13,000	100x16	177	72	1.00	0.40	9.5	RC3/8
YA-5K-10	Roll	8,400	150x22	224(193)	81.5	1.80	0.95	12.7	RC3/8
YA-5K-10F	Safety Lever	8,400	150x22	261(227)	81.5	1.84	0.95	12.7	RC3/8

Standard Accessories.... YA-3K 6mm bar Wrench,10Hex Pin Wrench, Plug NL-23PM

YA-5K Hook Spanner,10Hex Pin Wrench, Coupler Plug NL-23PM

For Grinding Wheel

Model	Throttle Type	Rotational Frequency	Grinding Wheel Size	Peripheral Speed	Overall Length	Head Height	Mass w/Guard	Max Air Consumption	Air Hose Size	Air Inlet Thread
		min-1	mm	m/min	mm	mm	kg	Nm ³ /min	mm	-
YA-3K-2	Roll	13,000	100x6x15	177	70	0.98	0.40	9.5	RC3/8	4,300
YA-3K-2L	Lever	13,000	100x6x15	172	70	1.03	0.40	9.5	RC3/8	4,300
YA-3K-2F	Safety Lever	13,000	100x6x15	172	70	1.03	0.40	9.5	RC3/8	4,300
YA-5K-30	Roll	7,600	180x6x22	242(208)	86	2.30	0.95	12.7	RC3/8	4,300
YA-5K-30F	Safety Lever	7,600	180x6x22	264(223)	86	2.28	0.95	12.7	RC3/8	4,300

Standard Accessories....YA-3K 32Hex Wrench, 6Hex Pin Wrench, 5Hex Pin Wrench, Plug NL-23PM

YA-5K 26Hex Wrench,6Hex Pin Wrench,5Hex Pin Wrench, Coupler Plug NL-23PM

For Wire Brush

Model	Throttle Type	Rotational Frequency	Wire Brush Size	Overall Length	Head Height	Mass w/o Brush	Max Air Consumption	Air Hose Size	Air Inlet Thread
		min-1	mm	mm	mm	kg	Nm ³ /min	mm	-
YA-5K-20	Roll	8,400	125X16	224(193)	81.5	1.60	0.95	12.7	RC3/8
YA-5K-20F	Safety Lever	8,400	125X16	261(227)	81.5	1.63	0.95	12.7	RC3/8

Standard Accessories....Hook Spanner,10Hex Pin Wrench, Coupler Plug NL-23PM

Caution YA-3K-2,-2L,-2F Use 100mm Off-Set Grinding Wheel only
YA-5K-30,-30F Use 180mm Off-Set Grinding Wheel only
Contact our staff for using Cutting Wheel or Cutter as you need to use additional part.



YOSHIDA MFG.CO.,LTD.

2019.10

※Specifications are subjects to change without notice.

Yoshida Tools

Light weight, Powerful and Durable
 High Blow frequency (90Hz)
 Low Air Consumption
 Providing high working efficiency

FLUX CHIPPER YFC Series

Direction of Chisel is easily adjusted (YFC-1)

Chisel can be easily exchanged (YFC-2,3)

NEEDLE SCALER YNS-1 Series

Needles can be easily exchanged

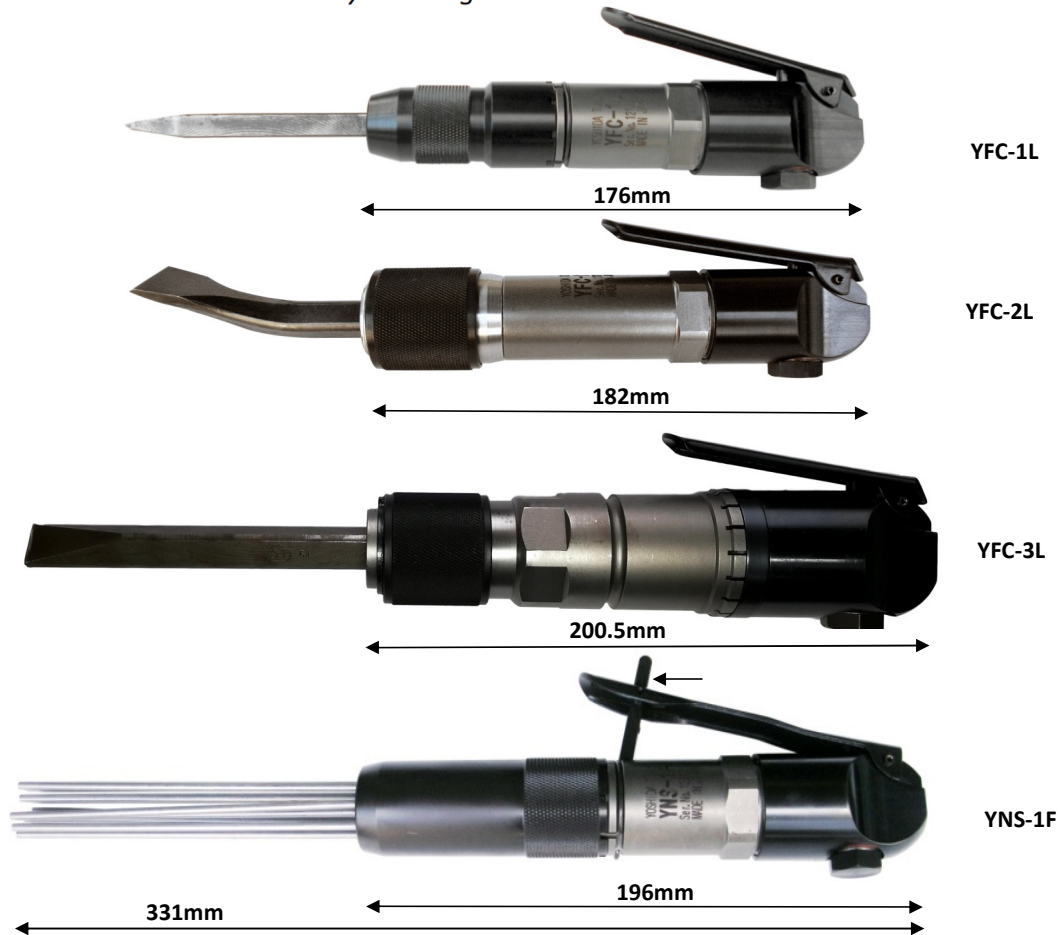

Specification

*Push Lock bar to release the lever

Model	Throttle Type	Blows	Piston Diameter	Stroke	Overall Length	Max Dia	Mass	Max Air Consumption	Air Hose Size	Air Inlet Thread
		Hz	mm	mm	mm	mm				
YFC-1L	Lever	90	20	16	176	36	0.8	0.14	6.3	RC-1/4
YFC-1F	Safety Lever	90	20	16	176	36	0.8	0.14	6.3	RC-1/4
YFC-2L	Lever	90	20	16	182	36	0.99	0.14	6.3	RC-1/4
YFC-2F	Safety Lever	90	20	16	182	36	0.99	0.14	6.3	RC-1/4
YFC-3L	Lever	60	25	20	200.5	44	1.5	0.18	9.5	RC-1/4
YFC-3F	Safety Lever	60	25	20	200.5	44	1.5	0.18	9.5	RC-1/4

Standard Accessory: NL-22PM Coupler Plug

Chisel Shank Size: (YFC-1) ϕ 11x20, (YFC-2,3) ϕ 12x25

Model	Throttle Type	Blows	Piston Diameter	Needle	Overall Length	Max Dia	Mass without Needle	Max Air Consumption	Air Hose Size	Air Inlet Thread
		Hz	mm	mm	mm	mm				
YNS-1L	Lever	90	20	3x180-12	196	36	0.97	0.14	6.3	RC-1/4
YNS-1F	Safety Lever	90	20	3x180-12	196	36	0.97	0.14	6.3	RC-1/4

Standard Accessory: NL-22PM Coupler Plug, Needle ϕ 3x180 12
 (2mm ϕ 2x130 24 Needle Model is also available)

※Specifications are subjects to change without notice.

YOSHIDA MFG.CO.,LTD.

2019.08



Yoshida Tools

BELT SANDERS YBS Series

*Light weight, Powerful and Durable
Low noise & Low working oscillation
Free Head Rotation Provides versatile Solution
for almost any application*

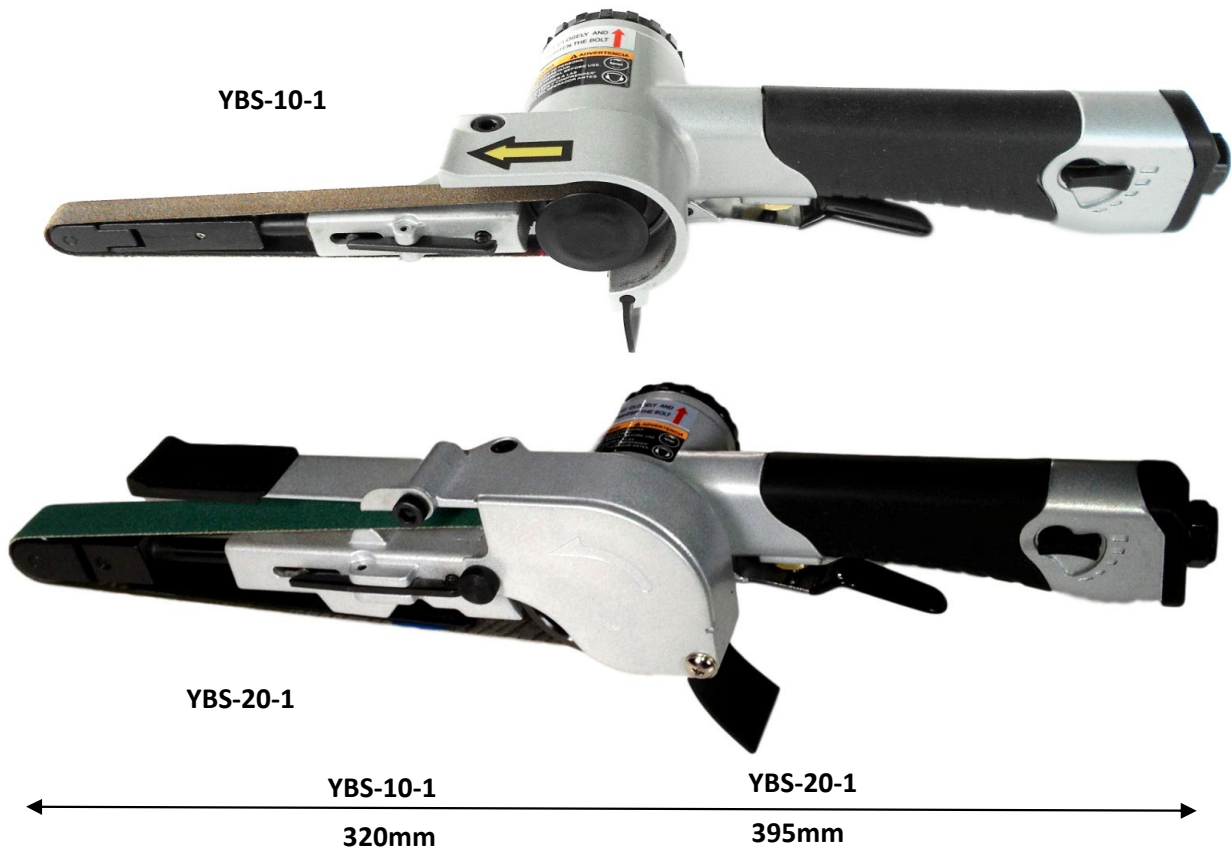

Specification

Model	Throttle Type	Exhaust Direction	Rotational Frequency	Belt Size	Overall Length	Mass	Max Air Consumption	Air Hose Size	Air Inlet Thread
			min-1	mm	mm	kg	Nm ³ /min	mm	-
YBS-10-1	Lever	Rear	16,000	10,12x330	320	0.93	0.11	9.5	RC1/4
YBS-20-1	Lever	Rear	16,000	20x520	395	1.4	0.11	9.5	RC1/4

Standard Accessory NL-22PM Coupler Plug, 1.5Hex, 4Hex Wrench(1each)

Grinding Belt #80,#100,#120 (1each)

※Specifications are subjects to change without notice.



YOSHIDA MFG.CO.,LTD.

2019.03

Yoshida Tools

INDUSTRIAL ONE HAND OPERATED AIR DRILL

YDR Series

- Light weight, Powerful and Durable
- Variable throttle control allows slow starting to protect the work pieces
- Rigid bearing design in output spindle provides minimum run-out with Yukiwa drill chuck
- Compact Hand Fitting body provides easy smooth hole drilling
- Ideal for general Industrial drilling tasks, such as drilling, hole sawing, valve guide reaming & wire brushing and air conditioner installation, engine work & auto body repair



SPECIFICATION

Model	Exhaust Direction	Rotational Frequency	Chuck Capacity	Spindle Type	Max Output	Stall Torque	Overall Length	Mass w/Drill Chuck	Max Air Consumption	Air Hose Size	Air Inlet Thread
		min-1	mm	Thread	Hp	Nm	mm	kg	Nm ³ /min	mm	-
YDR-28	Rear	2,800	8.0	3/8X24UNF	0.6	9.0	200	1.0	0.11	9.5	RC1/4
YDR-40	Rear	4,000	8.0	3/8X24UNF	0.6	8.0	200	1.0	0.11	9.5	RC1/4
YDR-60	Rear	6,000	8.0	3/8X24UNF	0.6	7.6	185	0.95	0.11	9.5	RC1/4

Standard Accessories....Drill Chuck Key JH-5, Coupler Plug NL-22PM

※Specifications are subjects to change without notice.



YOSHIDA MFG.CO.,LTD.

2019.03