

Ergonomic Solutions for Load Handling

# Materials Handling Products

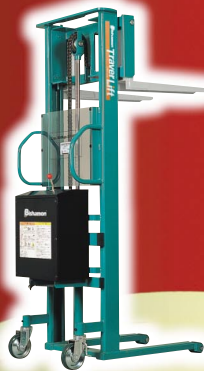



# MATERIALS HANDLING PRODUCTS INDEX



## FORK TYPE



■ Hand Pallet Trucks - P.03



■ Hydraulic Stackers - P.07



■ Skid Lifter - P.13

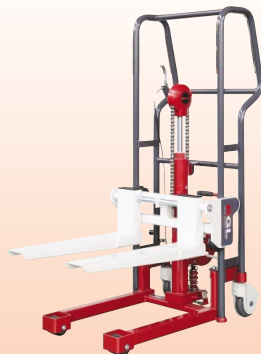

■ Platform Stacker - P.15

## STAINLESS



■ Hand Pallet Trucks - P.36



■ Hydraulic Stackers - P.37

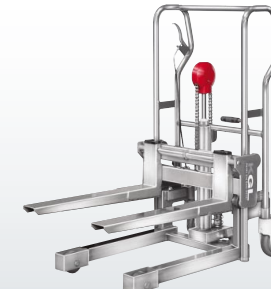

■ Platform Stacker - P.39

- Hand Pallet Trucks ..... P.03
- Hand Pallet Trucks 4ton & 5ton ..... P.05
- BDH Hand Pallet Trucks ..... P.05
- OPTION for Cold Storage and Water ..... P.06
- Hydraulic Stackers Series ..... P.07
- Skid Lifter ..... P.13
- Platform Stacker ..... P.15

### STAINLESS

- Hand Pallet Trucks ..... P.36
- Hydraulic Stackers ..... P.37
- Skid Lifter ..... P.38
- Platform Stacker ..... P.39

## TABLE TYPE



■ Mobile Lift Table - P.17



■ Mobile Work Positioner - P.18



■ Platform Stacker - P.19

## STAINLESS



■ Mobile Lift Table - P.40



■ Mobile Work Positioner - P.40



■ Platform Stacker - P.39

- Mobile Lift Table ..... P.17
- Mobile Work Positioner ..... P.18
- Platform Stacker ..... P.19
- Tilt Truck ..... P.21
- High Looper ..... P.22

### STAINLESS

- Platform Stacker ..... P.39
- Mobile Lift Table ..... P.40
- Mobile Work Positioner ..... P.40
- Tilt Truck ..... P.40

## STATIONARY TYPE



■ Super Low Profile Lift Tables - P.24



■ Heavy Duty Lift Tables - P.25



■ Electric Screw Drive Type Lift - P.29



■ Vario Screw Lift - P.30

## STAINLESS



■ Compact Lift Tables - P.41



■ Super Low Profile Lift Tables - P.41



■ Heavy Duty Lift Tables - P.42

- Compact Lift Tables ..... P.23
- Super Low Profile Lift Tables ..... P.24
- Heavy Duty Lift Tables ..... P.25
- Electric Screw Drive Type Lift ..... P.29
- Vario Screw Lift ..... P.30

### STAINLESS

- Compact Lift Tables ..... P.41
- Super Low Profile Lift Tables ..... P.41
- Heavy Duty Lift Tables ..... P.42

- REMODELING EXAMPLE ..... P.31

MOBILE TYPE

STATIONARY TYPE

FORK TYPE

TABLE TYPE

STATIONARY TYPE

# Hand Pallet Trucks

High Standards and Experienced Engineering provide Superior Quality !

## Blue Label - pallet trucks provide -

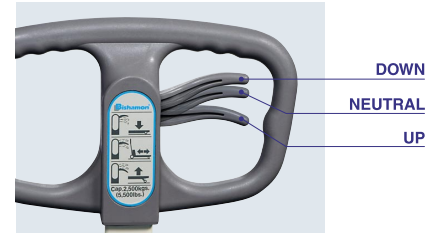

### Comfortable Molded Grip Handle

Molded handle design provides comfort and a strong grip

### 3 Position Fingertip Control

3 position Control Lever provides easy fingertip control of complete hydraulic system

### Standard Features



### Polyurethane Wheels

Aluminum hub steer wheels and aluminum hub fork(load) wheels are standard

### Lead Free Paint

Bishamon pallet trucks are painted with environmentally friendly lead free paint.

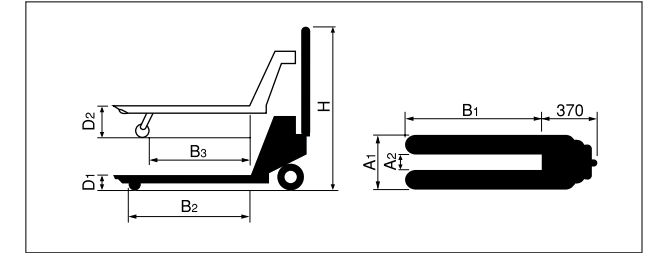

<b>A Standard Model</b>	2,000 Kgs. Capacity	Fork M/M Height	80 mm
<b>B Special Width Model</b>	2,000 Kgs. Capacity	Fork M/M Height	80 mm
<b>C Standard Model</b>	2,500 Kgs. Capacity	Fork M/M Height	80 mm
<b>D Standard Low Profile Model</b>	1,500 & 2,500 Kgs. Capacity	Fork M/M Height	65 mm
<b>E 3 Ton Capacity Model</b>	3,000 Kgs. Capacity	Fork M/M Height	83 mm
<b>F 50 mm Low Profile Model</b>	1,200 Kgs. Capacity	Fork M/M Height	50 mm
<b>G 40 mm Super Low Profile Model</b>	1,000 Kgs. Capacity	Fork M/M Height	40 mm

Model	Model No.	Capacity (Kg)	Width (mm)		Length (mm)		Height (mm)		Width (mm)	Length (mm)	Length (mm)	Weight (Kgs.)
			A <sub>1</sub>	B <sub>1</sub>	D <sub>1</sub>	D <sub>2</sub>	A <sub>2</sub>	B <sub>2</sub>				
A	BM20SS	2,000	520	810	80	200	214	675	525	72		
	BM20S		520	980	80	200	214	845	695	75		
	BM20M		520	1,070	80	200	214	935	785	79		
	BM20L		520	1,150	80	200	214	1,015	865	81		
	BM20C		685	1,070	80	200	379	935	785	85		
	BM20LL		685	1,220	80	200	379	1,085	935	88		
B	BMP20-48SS	2,000	480	810	80	200	174	675	525	71		
	BMP20-48S		480	980	80	200	174	845	695	75		
	BM20-60M		600	1,070	80	200	294	935	785	82		
	BM20-60LL		600	1,220	80	200	294	1,085	935	85		
C	BM25SS	2,500	520	810	80	200	214	675	525	86		
	BM25S		520	980	80	200	214	845	695	88		
	BM25M		520	1,070	80	200	214	935	785	89		
	BM25L		520	1,150	80	200	214	1,015	865	90		
	BM25C		685	1,070	80	200	379	935	785	97		
	BM25F		685	1,150	80	200	379	1,015	865	98		
D	BM25LL	2,500	685	1,220	80	200	379	1,085	935	99		
	BM15SS-L65		1,500	520	810	65	165	214	675	545	68	
	BM15M-L65			520	1,070	65	165	214	935	805	75	
	BM15LL-L65			685	1,220	65	165	379	1,085	955	83	
	BM25M-L65			520	1,070	65	165	214	935	805	85	
BM25LL-L65	685	1,220		65	165	379	1,085	955	95			
E	BM30SS	3,000	520	810	82.5	202.5	214	735	480	100		
	BM30S		520	980	82.5	202.5	214	905	650	103		
	BM30M		520	1,070	82.5	202.5	214	995	740	105		
	BM30L		520	1,150	82.5	202.5	214	1,075	820	107		
	BM30D		685	810	82.5	202.5	379	735	480	105		
	BM30C		685	1,070	82.5	202.5	379	995	740	107		
	BM30LL		685	1,220	82.5	202.5	379	1,145	890	110		
F	BM12SS-L50	1,200	520	810	50	140	214	665	555	68		
	BM12M-L50		520	1,070	50	140	214	1070	925	75		
	BM12LL-L50		685	1,220	50	140	379	1075	965	83		
G	BM10SS-L40	1,000	520	810	40	115	214	685	535	64		
	BM10S-L40		520	980	40	115	214	855	705	67		
	BM10M-L40		520	1,070	40	115	214	945	795	71		
	BM10C-L40		685	1,070	40	115	379	945	795	71		

## Optional Features



### Bogie Wheels

Bogie Wheels are standard with model BM30



### Parking Brake



### Wheels

Nylon Wheels - available with Model BM20 & 25 (Except Low Profile Model) as an option.

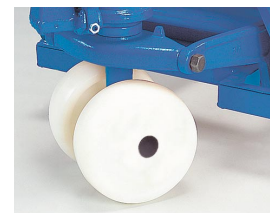



# Hand Pallet Trucks 4ton & 5ton

High capacity model Capacity 4000~5000kg

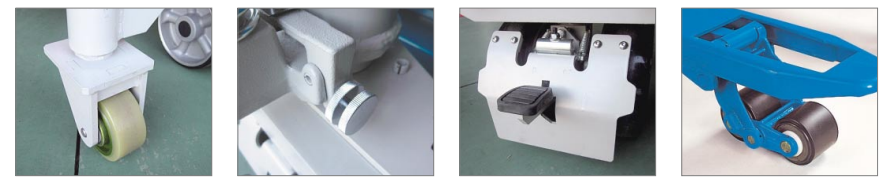

Auxiliary wheel Lowering Speed Controller Parking Brake with Foot Guard Bogie Wheels

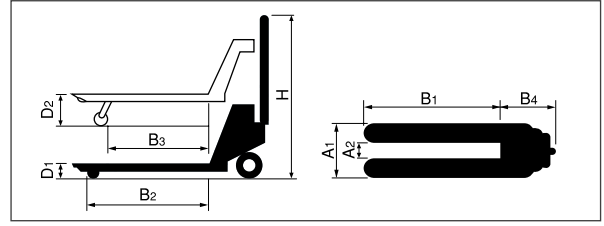

Model	Capacity (Kg)	Width (mm)		Length (mm)		Height (mm)		Length (mm)				Weight (Kgs.)
		A1	A2	B1	B2	D1	D2	A2	B2	B3	B4	
BM40M	4,000	520	685	1,070	992	83	202	214	992	759	410	155
BM40LL				1,220	1,139	906	414	175				
BM40L5				1,600	1,519	1,284	414	220				
BM50L4	5,000	685	85	1,500	1,432	205	205	285	1,432	1,197	416	260
BM50L6				1,800	1,732	1,496	416	300				
BM50L7				2,000	1,932	1,695	416	320				

Specifications are subject to change without notice.

# BDH Hand Pallet Trucks

With battery powered lifting and driving, anyone can operate them

Battery Powered Lift & Drive Models Capacity 1500kg



Capacity up to 1,500kg

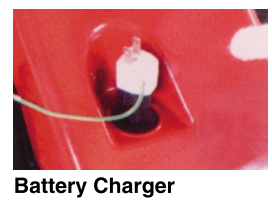

Battery Charger



Safety Switch



Simple Switches Emergency Stop Switch



Collapse Prevention Stand

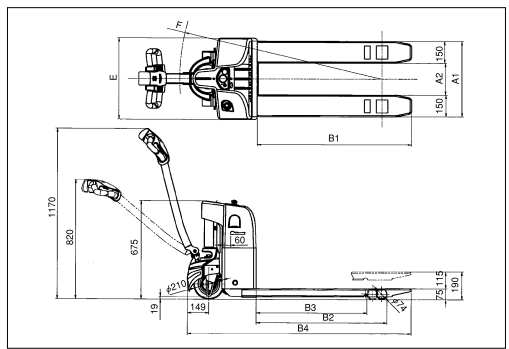

Model	Fork					Total Length	Total Width	Turning Radius	Weight (kg)
	External Width	Internal Width	Length						
	A1	A2	B1	B2	B3	B4	E	F	
BDH15M	520	220	1070	903	766	1541	560	R1405	210
BDH15S			980	813	676	1451		R1315	207
BDH15E			1220	1053	916	1691		R1555	213
BDH15-60M	600	300	1070	903	766	1541	600	R1405	211
BDH15-60LL			1220	1053	916	1691		R1555	215
BDH15C	685	385	1070	903	766	1541	685	R1405	217
BDH15LL			1220	1053	916	1691		R1555	220

# OPTION for Cold Strage and Water BISHAMON'S PROPOSAL

Options for the site where it is cold or wet

## OPTION 1 For the site that is cold region and cold strage



Standard Model

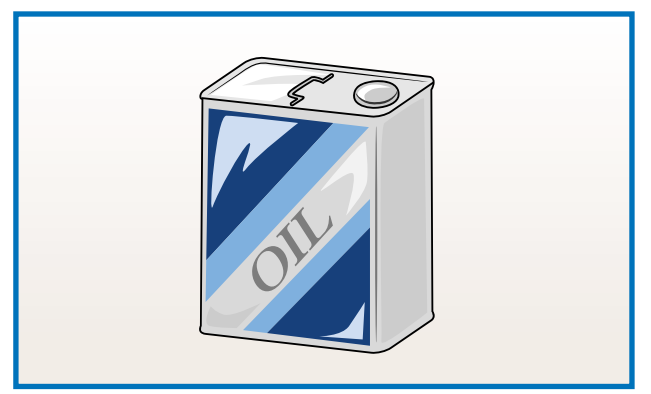

Hyd. Oil for cold temperature up to -15 °C

## OPTION 2 For the site which floor is wet



Standard parts are made of steel

Lowering valve with Stainless and QPQ coating

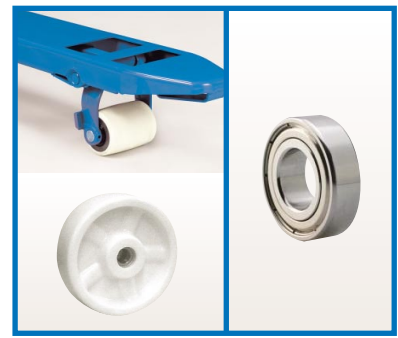

Nylon wheel + Stainless Bearing



Grease nipple on axles

## OPTION 3 For the site dripping water

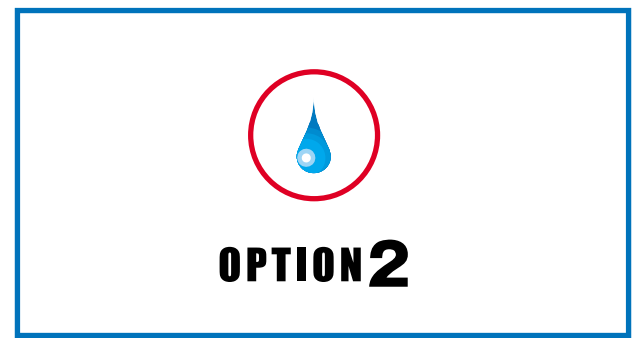

OPTION 2

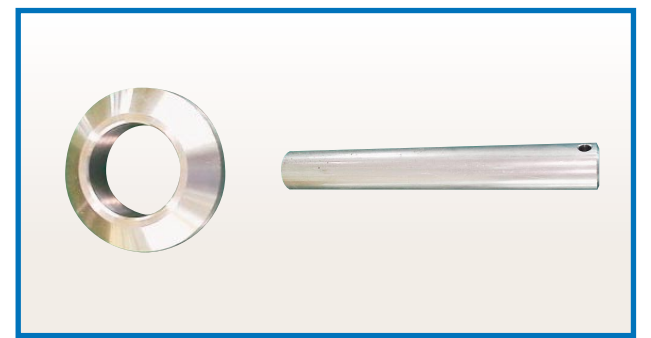

Axle and its bush are made of stainless



# Hydraulic Stackers Series

A full line-up of 55 models to meet a variety of needs

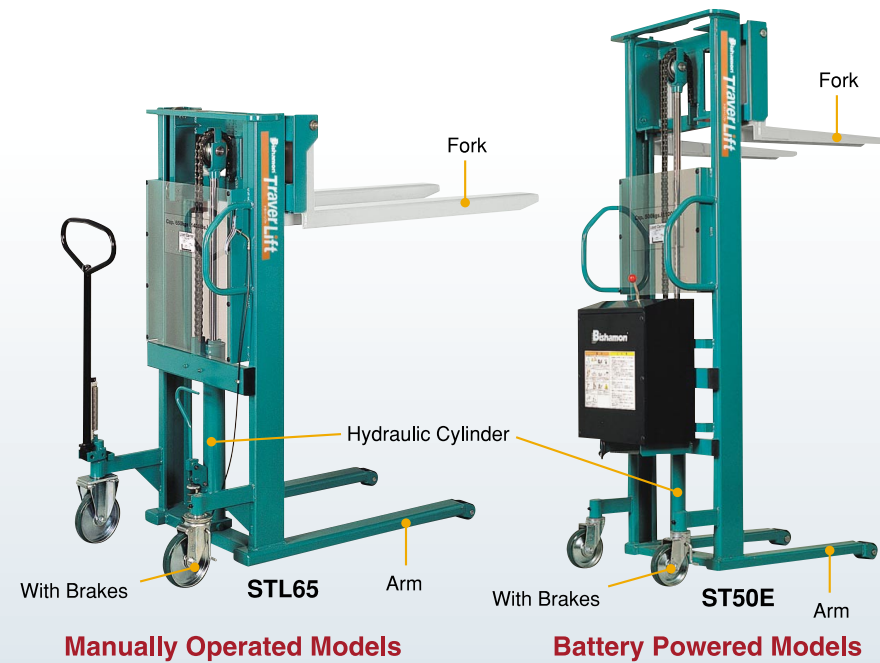

## Manually Operated Models Capacity 150~1000kg



STL15  
Lifting Height 750 Type



STL65  
Lifting Height 1200 Type



ST25  
Lifting Height 1500 Type

### Fork Types

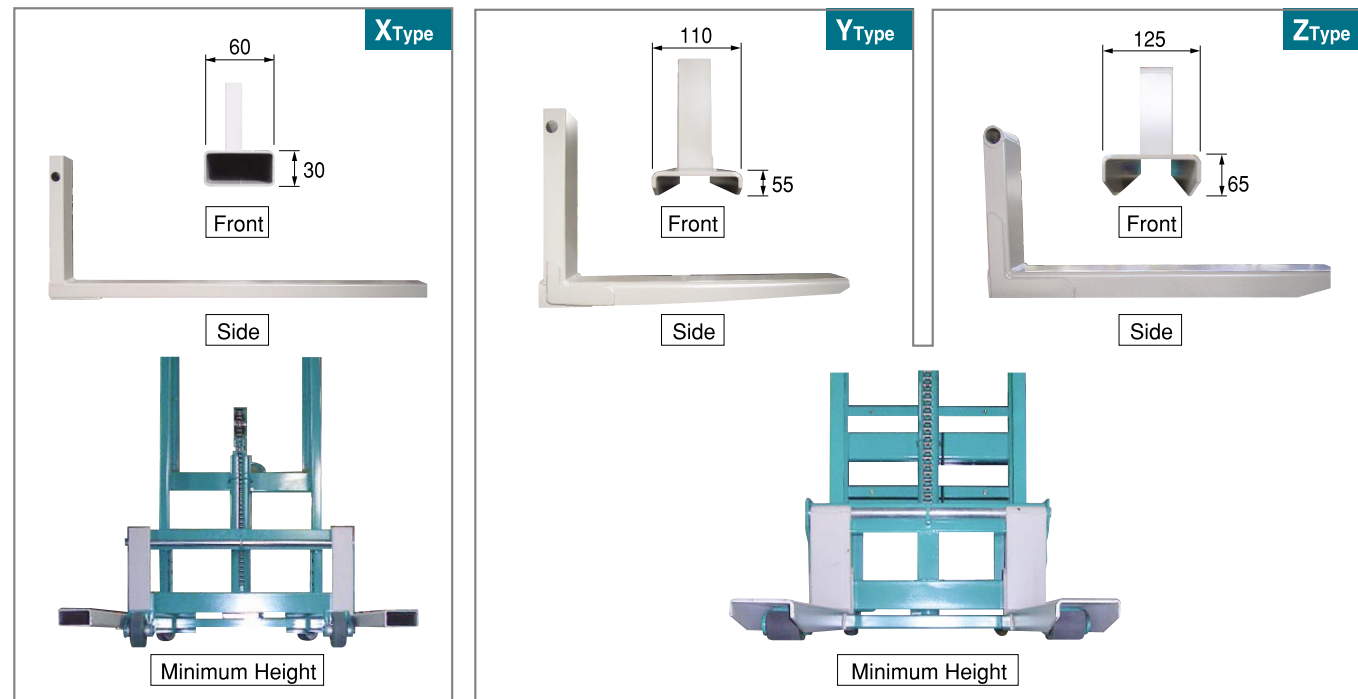

### Trivia!!

When the center of gravity of the load is between the base and center of the forks, the machine can be operated at maximum capacity. However, if the center of gravity is between the middle and tip of the forks, maximum capacity is decreased.

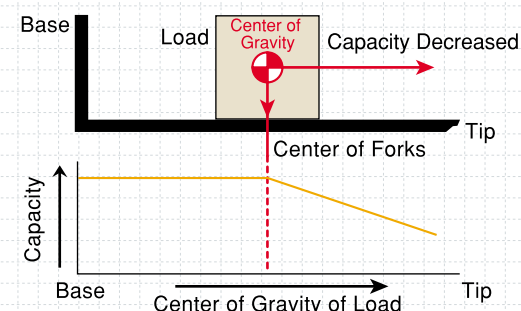

### Option



**Flexible Moving Handle**  
Capacity of over 650kg  
Comes standard



**Easy Lowering**  
by pulling lever  
Deadman design for safety  
(Manually Operated Models)



**Easy Lifting**  
by pumping pedal  
Pedal can be folded  
(Manually Operated Models)

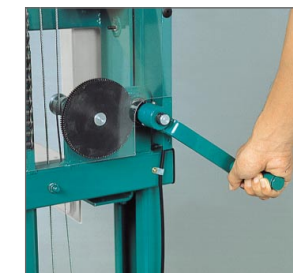

**Quick Lifting Device**  
(Manually Operated Models)

When placing an order, please be sure to write "Fast-uplifting device (H)"

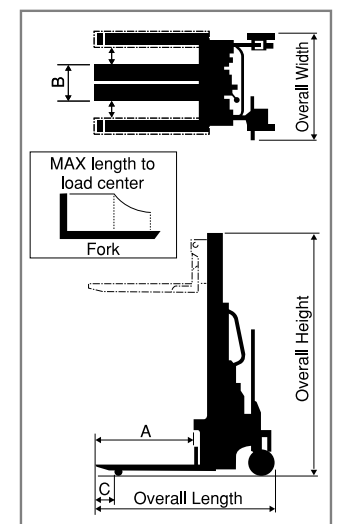

### Lifting Height 750 Type (Fork Height 90 - 840)

Model	Maximum Capacity (kg)	Fork Configuration	Fork (mm)			Arm (mm)			Pump Count (Number of Times)	Total Height (mm)	Total Width (mm)	Total Length (mm)	Wheels (Urethane)		Weight (kg)	Options
			Length A	Slide External Width B	Extended Width C	External Width	Internal Width	Gap with Floor					Diameter	Support Width		
STL15	150	X	750	125~628	277	502	360	26	27	1,233	645	1,198	80×32	100×32	57	×
STL38	380	Y	800	232~600	234	586	394	31	37	1,261	683	1,306	70×73	150×42	135	○

### Lifting Height 1200 Type (Fork Height 90 - 1290)

STL25	250	X	550	125~628	77	502	360	26	43	1,592	645	998	80×32	100×32	62	○
STL38	380	Y	600	232~558	119	544	352	31		1,666	641	1,099			70×73	
STL50	500			232~600	34	586	394		57	1,669	683	1,106	151			
STL65	650	Z	1,200	262~726	352	700	500	30	102	1,667	883	1,851	70×73	200×42	247	

### Lifting Height 1500 Type (Fork Height 90 - 1590)

ST25	250	X	550	125~628	77	502	360	26	53	1,892	645	998	80×32	100×32	67	○
ST38	380	Y	600	232~558	119	544	352	31		1,966	641	1,099			70×73	
ST50	500			232~600	34	586	394		71	1,969	683	1,106	156			
ST65	650	Z	1,200	262~726	352	700	500	30	127	1,967	883	1,851	70×73	200×42	252	
ST80	800		1,000									1,651			251	
ST100	1,000		800									1,451			250	

# Hydraulic Stackers

## Battery Powered Models Capacity 380~1000kg



STL38E

Lifting Height 1200 Type



ST50

Lifting Height 1500 Type



STW50E

Lifting Height 2420 Type

## Battery Powered Lift & Drive Models Capacity 380~980kg



ST50A

Lifting Height 1500 Type



STW65A

Lifting Height 2420 Type



**Easy Lifting and Lowering**  
Lifting and lowering speed can be controlled by the operation of lever.



**Separate Battery Charger/ AC100V**  
(Comes with battery)

### Option



**Battery Meter**  
Comes standard with electric drive types

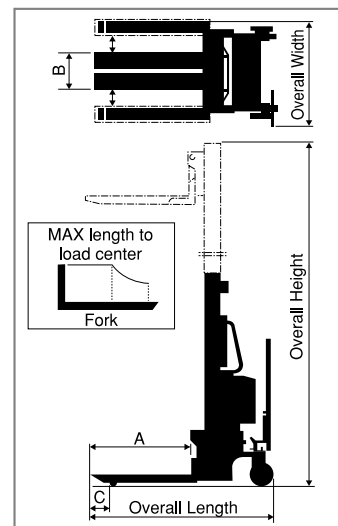

**Easy Lifting and Lowering**  
Lifting and lowering speed can be controlled by the operation of lever.



**Separate Battery Charger / AC100V**  
(Comes with battery)

### Option



**Battery Meter**  
Comes standard with electric drive types

### Lifting Height 1200 Type (Fork Height 90 - 1290)

Model	Maximum Capacity (kg)	Configuration	Fork (mm)			Arm (mm)			Total Height (mm)	Total Width (mm)	Total Length (mm)	Battery Capacity	Lifting Time (sec)	Wheels (Urethane)		Weight (kg)
			Length	Slide External Width	Extended Width	External Width	Internal Width	Gap with Floor						Diameter	Support	
STL38E	380	Y	600	232~558	119	544	352	1,666	641	1,075	12V36Ah/5Hr	16	70	150	151	
STL50E	500	Y	600	232~600	34	586	394	1,669	683	1,085	12V64Ah/5Hr	18	70	150	187	
STL65E	650	Z	1,200	262~726	352	700	500	1,667	883	1,889	12V64Ah/5Hr	28	70	200	318	

### Lifting Height 1500 Type (Fork Height 90 - 1590)

ST38E	380	Y	600	232~558	119	544	352	1,966	641	1,075	12V36Ah/5Hr	20	70	150	156
ST50E	500	Y	600	232~600	34	586	394	1,969	683	1,085	12V64Ah/5Hr	22	70	150	192
ST65E	650	Z	1,200	262~726	352	700	500	1,967	883	1,889	12V64Ah/5Hr	35	70	200	323
ST80E	800	Z	1,000	262~726	152	700	500	1,967	883	1,689	12V64Ah/5Hr	35	70	200	322
ST100E	1,000	Z	800	262~726	152	700	500	1,967	883	1,489	12V64Ah/5Hr	35	70	200	321

### Lifting Height 2420 Type (Fork Height 90 - 2510)

STW38E	380	Y	600	232~600	41	586	394	1,708~2,923	673	1,092	12V64Ah/5Hr	22	70	150	241
STW50E	500	Z	1,000	262~726	352	700	500	1,734~2,949	883	1,689	12V92Ah/5Hr	30	70	200	363
STW65E	650	Z	800	262~726	152	700	500	1,734~2,949	883	1,489	12V92Ah/5Hr	30	70	200	358

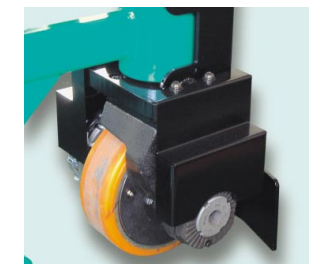

**Compact Drive unit**



**Easy Control Lever**  
Easy and Smooth Driving with Finger Control

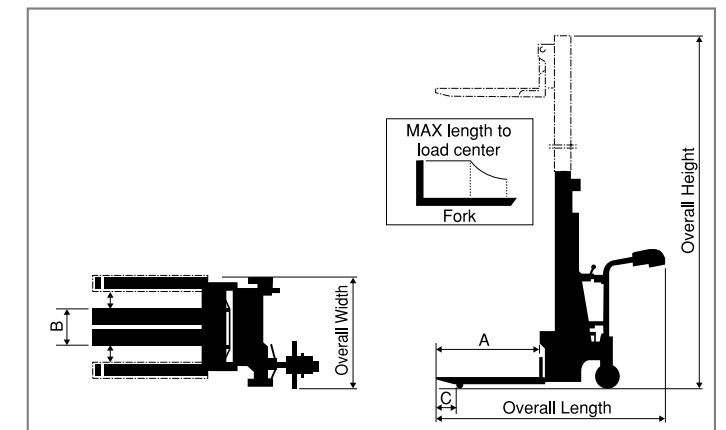

### Lifting Height 1500 Type (Fork Height 90 - 1590) (Speed While Loaded 2.3 km/h)

Model	Maximum Capacity (kg)	Configuration	Fork (mm)			Arm (mm)			Total Height (mm)	Total Width (mm)	Total Length (mm)	Battery Capacity	Lifting Time (sec)	Wheels (Urethane)		Weight (kg)
			Length	Slide External Width	Extended Width	External Width	Internal Width	Gap with Floor						Diameter	Support	
ST50A	500	Y	600	232~600	34	586	394	1,969	765	1,519	12V64Ah/5Hr	22	70	150	209	
ST98A	980	Z	800	262~726	152	700	500	1,967	876	1,826	12V92Ah/5Hr	35	70	180	338	

### Lifting Height 2420 Type (Fork Height 90 - 2510)

STW38A	380	Y	600	232~600	34	586	394	1,708~2,923	756	1,525	12V64Ah/5Hr	22	70	150	258
STW65A	650	Z	800	262~726	152	700	500	1,734~2,949	876	1,826	12V100Ah/5Hr	30	70	200	374



# Hydraulic Stackers

Wide Models Capacity 200~1000kg



ST100EWN



WN Type

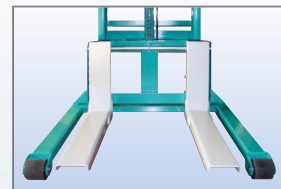

The width of the arms was extended so they would not interfere within the adjustable range of the forks.

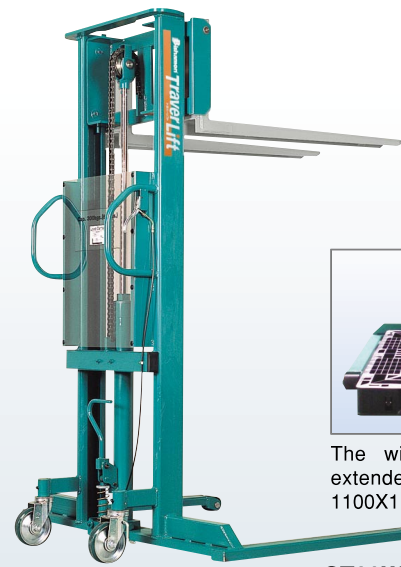

ST30WW



WW Type

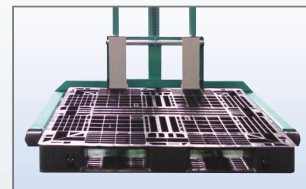

The width of the arms was extended to be able to lift 1100X1100 pallets.

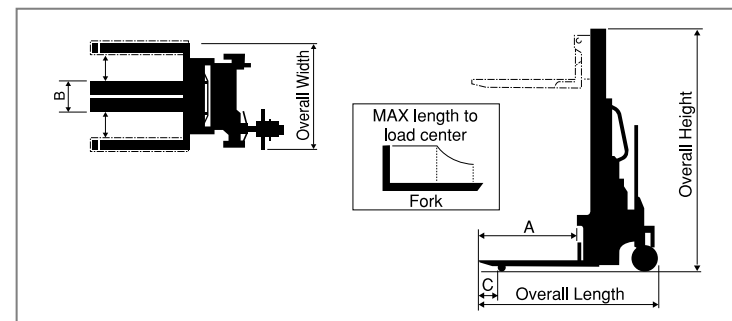

## Manually Operated Type (Fork Height 90 - 1590)

Model	Maximum Capacity (kg)	Fork (mm)			Arm (mm)			Pump Count (Number of Times)	Total Height (mm)	Total Width (mm)	Total Length (mm)	Wheels (Urethane)		Weight (kg)	Options Fast Traverse							
		Configuration	Length A	Slide External Width B	Extended Width C	External Width	Internal Width					Gap with Floor	Front Wheels			Support Wheels						
ST20WW	200	Y	1,000	232~558	319	1,375	1,175	31	1,966	1,375	1,499	70×73	150×42	159	○							
ST30WW	300			232~600	234											871	679	71	1,969	875	1,106	193
ST38WN	380			232~558	119											871	679	71	1,966	875	1,106	132
ST50WN	500	232~600	34	166																		
ST80WW	800	Z	1,000	262~726	152	1,400	1,200	30	1,967	1,400	1,651	200×42	276									
ST100WN	1,000			262~688	152										900	700	934	1,451	260			

## Battery Powered Raising/ Lowering Type (Fork Height 90 - 1590)

Model	Maximum Capacity (kg)	Fork (mm)			Arm (mm)			Total Height (mm)	Total Width (mm)	Total Length (mm)	Battery Capacity	Lifting Time (sec)	Wheels (Urethane)		Weight (kg)	
		Configuration	Length A	Slide External Width B	Extended Width C	External Width	Internal Width						Gap with Floor	Front Wheels		Support Wheels
ST30EWW	300	Y	1,000	232~600	234	1,375	1,175	31	1,969	1,375	1,485	12V64Ah/5Hr	22	70×73	150×42	229
ST50EWN	500															
ST80EWW	800	Z	1,000	262~726	152	1,400	1,200	30	1,967	1,400	1,689	12V64Ah/5Hr	35	70×73	200×42	347
ST100EWN	1,000															

## Battery Powered Raising/ Lowering Type (Fork Height 90 - 1590) (Speed While Loaded 2.3 km/h)

Model	Maximum Capacity (kg)	Fork (mm)			Arm (mm)			Total Height (mm)	Total Width (mm)	Total Length (mm)	Battery Capacity	Lifting Time (sec)	Wheels (Urethane)		Weight (kg)	
		Configuration	Length A	Slide External Width B	Extended Width C	External Width	Internal Width						Gap with Floor	Front Wheels		Support Wheels
ST80AWW	800	Z	1,000	262~726	152	1,400	1,200	30	1,967	1,400	2,026	28	70×73	180×50	364	
ST98AWN	980															800

MEMO



# Skid Lifter

LV Series Skid Lifts provide lifting power for skid-transported materials or work in progress.

## Manually Operated Models Capacity 500~1000kg



The foot pump is a safe and compact collapsible type (same for LV50/ LV100)



**Easy Lowering**  
by pulling lever Deadman design for safety (All Models)

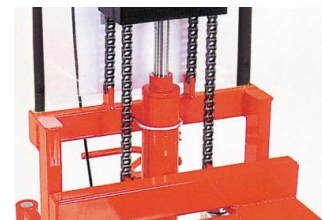

The Bishamon original hydraulic pump and cylinder are extremely reliable

### Examples of Use



Set at the same height as the conveyor belt and slide things over



Match the height to machinery to match levels



Improve efficiency by lifting mesh pallets to remove items underneath them

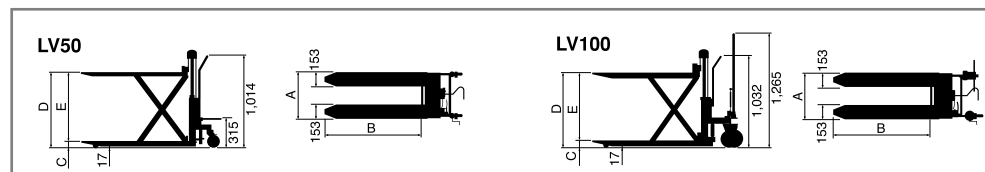

Model	Maximum Capacity (kg)	Fork (mm)					Total Width (mm)	Total Length (mm)	Pump Operation Count (Number of Times)	Wheels (mm)		Weight (kg)				
		External Width	Length	Minimum Height	Maximum Height	Lifting Height				Urethane						
										Front Wheel Diameter	Rear Wheel Diameter					
LV50NSS	500	460	810	83	613	530	543	1,302	28	70	150	87				
LV50SS		520					603					88				
LV50N		460	1,080		833	750	543					39	1,573	70	150	100
LV50		520					603									101
LV50W		685					768									106
LV100	1,000	520	1,080	83	833	750	728	1,685	71	70	200					136
LV100W		685					893									160

## Battery Powered Models Capacity 500~1000kg

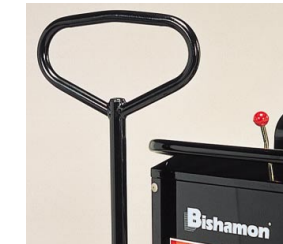

**Offset Handle**  
Model LV100E Series feature an offset steering handle



**Easy Control Lever**  
for lifting and lowering

Model	Maximum Capacity (kg)	Fork (mm)					Total Width (mm)	Total Length (mm)	Lifting Time (S)	Lowering Time (S)	Battery Capacity	Wheels (mm)		Weight (kg)					
		External Width	Length	Minimum Height	Maximum Height	Lifting Height						Urethane							
												Front Wheel Diameter	Rear Wheel Diameter						
LV50NSSE	500	460	809	83	603	520	555	1,300	7	Adjustable	DC12V 36Ah/5Hr	70	150	122					
LV50SSE		520					603							123					
LV50NE		460	1,080		833	750	555							10	Adjustable	DC12V 36Ah/5Hr	70	150	135
LV50E		520					603												136
LV50WE		685					768												141
LV100E	1,000	520	1,080	83	833	750	728	1,725	18	Adjustable	DC12V 36Ah/5Hr	70	200						179
LV100WE		685					893												187

## Battery Powered Lift & Drive Models Capacity 980kg

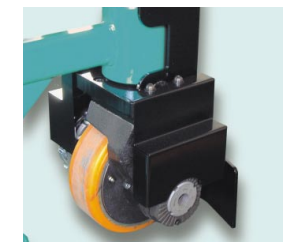

**Compact Drive unit**



**Easy Control Lever**  
Easy and Smooth Driving with Finger Control

Model	Maximum Capacity (kg)	Fork (mm)					Total Width (mm)	Total Length (mm)	Lifting Time (S)	Lowering Time (S)	Battery Capacity	Wheels (mm)		Weight (kg)
		External Width	Length	Minimum Height	Maximum Height	Lifting Height						Urethane		
												Front Wheel Diameter	Rear Wheel Diameter	
ALV98	980	520	1,080	83	833	750	682	2,040	18	Adjustable	DC12V 92Ah/5Hr	70	180	219
ALV98W		685					847							227



# Platform Stacker

Capacity 200~400kg

Handy and Easy Moving Platform Stacker

## Fork Models

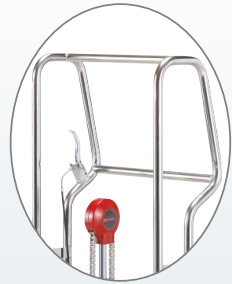

**Stainless Steel Handle**  
If the model number includes an **S**, the frame can be made stainless steel.  
E.g. : **KGL20SF**



KGL20F

KGL40HF

Upper Position (445mm)

Lower position (290mm)



### Dual Brake System

The brake system feature engages the brake of both steering casters in any position with one motion.



### Adjustable Foot pedal

Foot pedal is adjustable into two positions for operator comfort with the upper position providing more travel per stroke.

### Adjustable Speed Improves Safety When Lowering/ Simple Auto Fast Traverse Improves Efficiency

With no load (or a light load), lowering is twice as fast as when there is a load

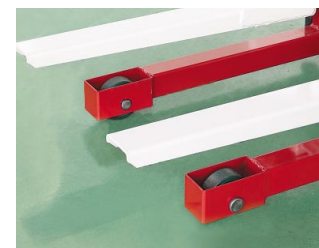

Caster Cover

## Examples of Use



Model	Maximum Capacity (kg)	Fork			Arm External Width (mm)	Total Height (mm)	Total Width (mm)	Total Length (mm)	Pump Operation Count (Number of Times)	Wheels (mm)		Weight (kg)	Stainless Steel Handle Model
		Height (mm)	Length (mm)	Slide External Width (mm)						Urethane	Front Wheels		
KGL20F	200	95~750	600	148~454	454	1,000	571	1,075	16 (9)	φ80	φ125	56	KGL20SF
KGL20HF		95~1,120											1,344
KGL40F	400	95~750		232~495	495	1,020	625	1,133	27 (15)	φ70	92	KGL40SF	
KGL40HF		95~1,090										1,375	39 (20)

Inside ( ) is for no load

# Platform Stacker

Capacity 200kg

Assist in fuelling machinery or matching levels for shelves. Even heavy loads are easy with battery powered lifting!

## Fork Models Screw Driven Type

Despite being powered for both lifting and lowering, the body is lightweight.

- Screw cylinders mean zero natural lowering!
- Vertical movement is slow and safe.



KGL20NHF

Drive Type	Electric Screw Cylinder
Power Source	DC24V (Specialized Battery)
Operating Method	Push Switches
Lifting Time	Approximately 37 seconds (no load)
	Approximately 55 seconds (rated load)
Lowering Time	Approximately 37 seconds (no load)
	Approximately 37 seconds (rated load)
Charge Time	Approximately 8 hours



### Simple Up/Down Push Buttons

With a remote control, buttons can be used even from the side the load is on.  
Uses inching method, holding down the button while operating



### Lightweight, Compact Battery Removable with One Hand

- Emergency stop button installed.
- Emergency lowering button installed.

Lightweight, Using Aluminum Cylinders Plated Chains

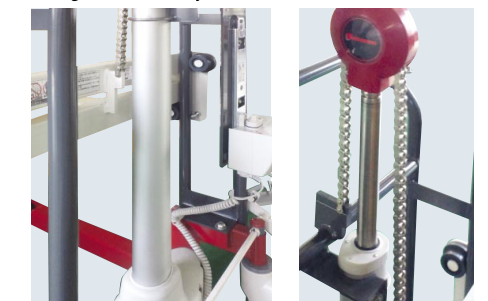

The cylinders for medical use are used and therefore very quiet while operating.



### Compact Battery Charger.

With an extra battery (sold separately), long-term use is possible.



### Dual Brake System

The brake system feature engages the brake of both steering casters in any position with one motion.



Cylinders also look very clean, and are perfect for use in clean environments.  
Note: Not water resistant.

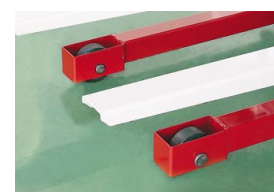

Caster Cover

Model	Maximum Capacity (kg)	Fork			Arm External Width (mm)	Total Height (mm)	Total Width (mm)	Total Length (mm)	Wheels (mm)		Weight (kg)
		Height (mm)	Length (mm)	Slide External Width (mm)					Urethane	Front Wheels	
KGL20NHF	200	95~1,060	600	148~454	454	1,344	571	963	φ80	φ125	57



# Mobile Lift Table

Capacity 150~800kg

BX Series add the value of mobility to a table

## Manually Operated Model



The BX15 handle is collapsible.



BX15

BX15W

Model	Maximum Capacity (kg)	Table Dimensions WidthXLength (mm)	Table Height (mm)	Total Height (mm)	Total Width (mm)	Total Length (mm)	Wheels	Adjustable Wheels	Pumping Count (Number of Times)	Weight (kg)	Options
											Hakacell
BX15W	150	500X813	380~1,350	898	500	1,046	φ100 Rubber	Support Wheels	31	93	○
BX15	150	450X700	215~733	798	450	854			15	33	○ (3sides)
BX30	300	500X813	290~867	898	500	1,008			25	69	○
BX30W	300	518X1,010	433~1,578	961	520	1,270	φ150 Urethane	Support Wheels	64	138	○
BX50	500		438~998	961	520	1,195			50	112	○
BX50SW	500	460X650	419~1,004	940	460	938	φ125 Urethane	66	102	○	
BX80	800	518X1,010	438~998	961	520	1,270	φ150 Urethane	67	115	○	

## Battery Powered Model

Lift and lower using dial Speed is adjustable



Battery charger installed



BX50B

BX30WB

Model	Maximum Capacity (kg)	Table Dimensions WidthXLength (mm)	Table Height (mm)	Total Height (mm)	Total Width (mm)	Total Length (mm)	Wheels	Adjustable Wheels	Lifting Time (sec)	Lifting Count (Number of Times)	Battery	Weight (kg)	Options
													Hakacell
BX15WB	150	500X813	380~1,380	890	500	1,072	φ100 Rubber	Support Wheels	10	110	12V/18AHX2 (Shielded)	129	○
BX30B	300		290~860						9				106
BX30WB	300	518X1,010	430~1,600	954	520	1,264	φ150 Urethane	Support Wheels	13	100	12V/26AHX2 (Shielded)	183	○
BX50B	500		440~1,015						11				110
BX80B	800	440~1,000	15	100	163	○							

## Examples of Use



# Mobile Work Positioner

Collapsed Capacity 10~600kg

ESX Series are fully adjustable, weight sensitive, self-leveling, mobile positioners with lifting function



ESX40

ESX21

ESX10

Model	Adjustable Range (kg)	Table Dimensions WidthXLength (mm)	Table Height (mm)	Total Height (mm)	Total Width (mm)	Total Length (mm)	Wheels	Adjustable Wheels	Weight (kg)	Options
										Hakacell
ESX05	10~50	450X700	262~659	798	450	836	φ100 Rubber	Support Wheels	38	○ (3 sides)
ESX08	20~80		262~650							○
ESX10	30~100		262~659							○
ESX10L	40~100	500X813	352~787	898	500	998	φ125 Urethane	62.5	○	
ESX21	80~210		352~772							
ESX21L	55~210	518X1,010	374~803	941	520	1,191	φ150 Urethane	104	115	
ESX40	100~400		374~794							
ESX60	220~600		393~813							

## Self-Leveling Functions

As the load weight changes, the table either raises or lower, keeping the top of the load at a convenient height.



**Fully Adjustable**  
Weight Selector Pointer travels along weight scale to highlight capacity as knob is turned

## Load and Height Chart (Model ESX21)

The above chart shows the ESX21 at a setting of 210Kgs. and 80Kgs.

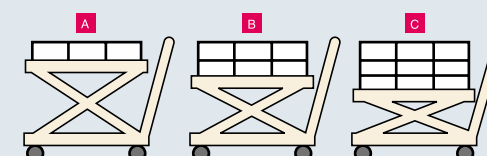
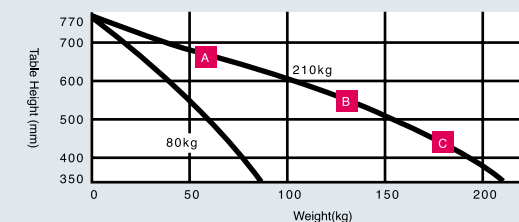

## Examples of Use





# Platform Stacker

Capacity 250~450kg

Handy and Easy Moving Platform Stacker

## Table Models

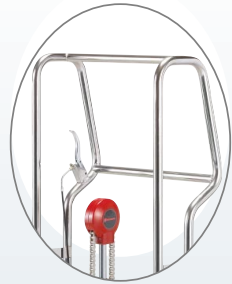

**Stainless Steel Handle**  
If the model number includes an **S**, the frame can be made stainless steel.  
E.g. : **KGL20SF**



KGL25

KGL45H

Upper Position (445mm)

Lower position (290mm)



### Dual Brake System

The brake system feature engages the brake of both steering casters in any position with one motion.



### Adjustable Foot pedal

Foot pedal is adjustable into two positions for operator comfort with the upper position providing more travel per stroke.

### Adjustable Speed Improves Safety When Lowering/ Simple Auto Fast Traverse Improves Efficiency

With no load (or a light load), lifting is twice as fast as when there is a load

## Examples of Use



Model	Maximum Capacity (kg)	Table		Arm External Width (mm)	Total Height (mm)	Total Width (mm)	Total Length (mm)	Pump Operation Count (Number of Times)	Wheels (mm)		Weight (kg)	Stainless Steel Handle Model
		Height (mm)	Width×Length (mm)						Front Wheels	Rear Wheels		
KGL25	250	150~820	540×600	480	1,000	568	1,033	16 (9)	φ125	φ125	55	KGL25S
KGL25H		150~1,170			1,344							23 (13)
KGL45	450	150~820	600×650	515	1,020	625	1,088	27 (15)	φ125	φ125	78	KGL45S
KGL45H		150~1,170			1,375							39 (20)

Inside ( ) is for no load

# Platform Stacker

Capacity 200kg

Assist in fuelling machinery or matching levels for shelves. Even heavy loads are easy with battery powered lifting!

## Table Models Screw Driven Type

Despite being powered for both lifting and lowering, the body is lightweight.

- Screw cylinders mean zero natural lowering!
- Vertical movement is slow and safe.



KGL20NH

Drive Type	Electric Screw Cylinder
Power Source	DC24V (Specialized Battery)
Operating Method	Push Switches
Lifting Time	Approximately 37 seconds (no load)
	Approximately 55 seconds (rated load)
Lowering Time	Approximately 37 seconds (no load)
	Approximately 37 seconds (rated load)
Charge Time	Approximately 8 hours



### Simple Up/Down Push Buttons

With a remote control, buttons can be used even from the side the load is on.  
Uses inching method, holding down the button while operating



### Lightweight, Compact Battery Removable with One Hand

- Emergency stop button installed.
- Emergency lowering button installed.

Lightweight, Using Aluminum Cylinders Plated Chains

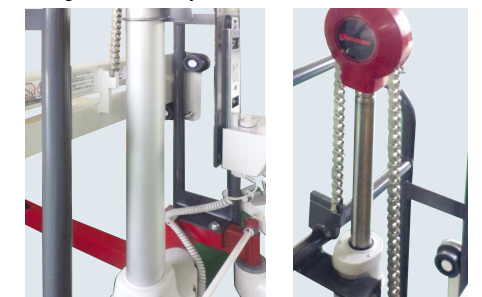

The cylinders for medical use are used and therefore very quiet while operating.



### Compact Battery Charger.

With an extra battery (sold separately), long-term use is possible.



### Dual Brake System

The brake system feature engages the brake of both steering casters in any position with one motion.



Cylinders also look very clean, and are perfect for use in clean environments.

Note: Not water resistant.

Model	Maximum Capacity (kg)	Table		Arm External Width (mm)	Total Height (mm)	Total Width (mm)	Total Length (mm)	Wheels (mm)		Weight (kg)
		Height (mm)	Width×Length (mm)					Front Wheels	Rear Wheels	
KGL20NH	200	150~1,130	541×600	480	1,344	569	919	φ125	φ125	58



# Tilt Truck

Capacity 150~250kg

Improve work efficiency from transport to turning over.



Model	Maximum Capacity (kg)	Bucket			Total Height (mm)	Total Width (mm)	Total Length (mm)	Total Height When Tilted (mm)	Pump Count (Number of Times)	Weight (kg)
		Lip Height (mm)	Height (mm)	Capacity (m³)						
DR15	150	564	690	0.12	798	535	1,022	988	18	51
DR25	250	595	797	0.27	898	685	1,301	1,192	23	93

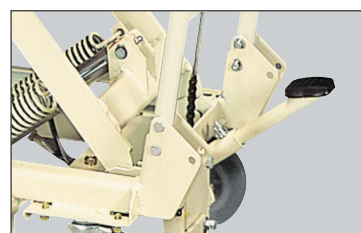

Safe design using a foot pedal, so everyone can use it without worry.

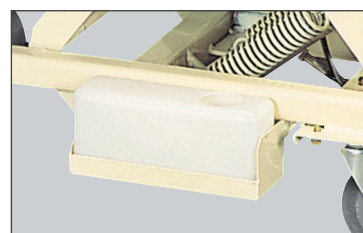

Cartridge installed to catch oil.

## Examples of Use



Work can be handled easily even by women



- Compact design for the tilt truck lets it dock with the tip conveyor. Since it no longer juts out into pathways, it makes finding and laying out routes much easier.
- Urethane wheels are available as an option.

# High Looper

Capacity 150~250kg

Excellent at speeding up slow input processes.



- The repeating cylinder allows smooth tipping.
- The height for tilting can be specified.
- Previous tilt trucks can be used as well with attachments.
- Safety devices such as hand and foot guards.
- Floor lock ensures stability.
- 3-axle setup allows for tight maneuvering.
- Unique lock device enables safe operation.

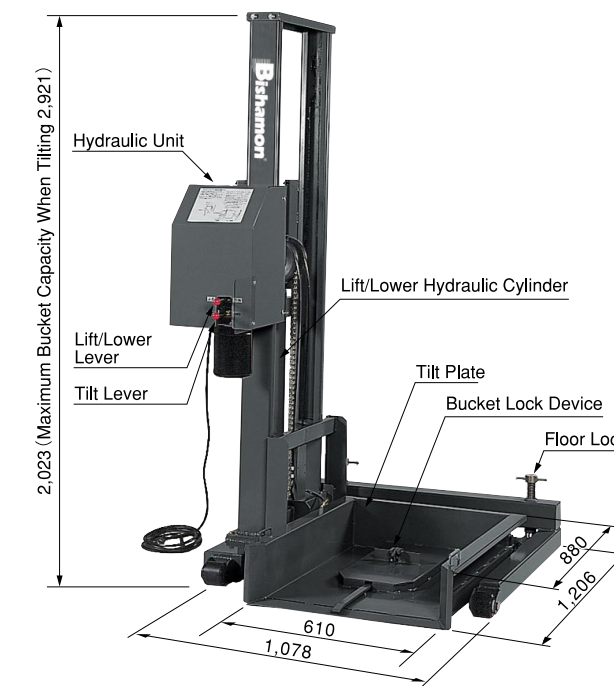

## Sold Separately



- Bucket DS15 (capacity 120L)
- Bucket DS25 (capacity 270L)

## High Looper

Model	Capacity (kgs)	Total Height (mm)	Total Width (mm)	Total Length (mm)	Maximum Height When DS Set (mm)	Lift Time (sec)		Tilt Time (sec)		Power Source (V)	Motor (KW)	Weight (kg)
						50Hz	60Hz	50Hz	60Hz			
HTR25	250	2,014	1,229	1,206	2,921	33	27	12	10	AC100V	0.56	250

## DS

Model	Capacity (kgs)	Bucket			Total Height (mm)	Total Width (mm)	Total Length (mm)	Weight (kg)
		Lip Height (mm)	Height (mm)	Capacity (m³)				
DS15	150	563	689	0.12	798	535	1,007	36
DS25	250	582	784	0.27	898	685	1,292	66



# Compact Lift Tables

X Series fits the need for maximum space efficiency

## Chibichan X Capacity 100~750kg

Hydraulic Unit Size



E : 325X350X160



Foot Pedal Type

X50C



Electric Operated Type

X75A-B



2-Stage Type

2X050510B-B

Model	Maximum Capacity (kg)	Lifting Height (mm)	Table Dimensions (mm)				Motor (kw)	Lifting Speed (sec)		Weight (kg)	Hydraulic Unit	Cable (m)		High Pressure Hose (m)		
			Width	Length	Minimum Height	Maximum Height		50Hz	60Hz			Power Source	Operating SW			
<b>3 Phase 200V</b>																
X050406A-B	500	390	460	650	140	530	0.375	14	12	82	E	5.3	5.3	2		
X50SA-B		630			210	840		22	18	111						
X50A-B		650			150	800		20	16	126						
X75A-B	750	650	518	1,010	150	800	Internal	28	23	127	Internal	4.7	3	-		
2X050510A-B	500	1,170	235	1,405	29	24		142								
<b>Single Phase 100 V</b>																
X10B-B	100	400	500	650	131	531	0.2	12	10	63	Internal	5.3	5.3	-		
X20B-B	200	565			150	715		34	28	82						
X25B-B	250	630			210	840		22	18	111						
X050406B-B	500	390	460	650	140	530	0.4	14	12	58	E	5.3	5.3	2		
X50SB-B		630			210	840		22	18	111						
X50B-B		650			150	800		20	16	133						
X75B-B	750	650	518	1,010	150	800	Internal	28	23	134	Internal	4.7	3	-		
2X050510B-B	500	1,170	235	1,405	29	24		140								
<b>Foot Pedal Type</b>																
X20C	200	400	500	650	131	531	Foot Pedal Type	-	-	-	Internal	-	-	-		
X25C	250	565			150	715									115	116
X50C	500	650			150	800									115	116
X75C	750	650	518	1,010	150	800	Foot Pedal Type	-	-	-	Internal	-	-	-		
2X050510C	500	1,170	235	1,405	29	24									128	

## Mini X Capacity 300~500kg



X050815B

Model	Maximum Capacity (kg)	Lifting Height (mm)	Table Dimensions (mm)				Motor (kw)	Lifting Speed (sec)		Weight (kg)	Hydraulic Unit	Cable (m)		High Pressure Hose (m)
			Width	Length	Minimum Height	Maximum Height		50Hz	60Hz			Power Source	Operating SW	
<b>3 Phase 200V</b>														
X030612A-B	300	800	600	1,200	150	950	0.375	16	14	166	Internal	4.7	3	-
X030812A-B			800							191				
X030615A-B			600							186				
X030815A-B	800	196	1,500	150	950	0.375	20	17	186	Internal	4.7	3	-	
X050612A-B	600	168												
X050812A-B	800	193												
X050615A-B	600	190	1,500	150	950	0.375	28	24	190	Internal	4.7	3	-	
X050815A-B	800	200												
<b>Single Phase 100 V</b>														
X030612B-B	300	800	600	1,200	150	950	0.4	19	16	161	Internal	4.7	3	-
X030812B-B			800							186				
X030615B-B			600							181				
X030815B-B	800	191	1,500	150	950	0.4	25	21	191	Internal	4.7	3	-	
X050612B-B	600	163												
X050812B-B	800	188												
X050615B-B	600	185	1,500	150	950	0.4	43	36	185	Internal	4.7	3	-	
X050815B-B	800	195												

Regarding Specifications (see pages 23, 24)

(L) X ○ ○ - B



※Push buttons are standard

Let go and it stops

# Super Low Profile Lift Tables

LX Series allows easy loading and unloading of cargo without requiring a below-floor level pit

## Capacity 250~3000kg



LX100N-B



LX300N-B

Safety Toe Guard

Minimum Height

LX25 Series ▶ 59mm

LX50 Series ▶ 60mm

LX100 Series ▶ 76mm

LX200 Series ▶ 95mm

LX300 Series ▶ 134mm



Hydraulic Unit is separate from lift table (all Models)

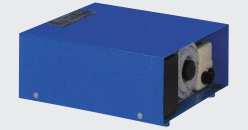

G : 3·1 Phase Unit  
W325X L350X H160mm

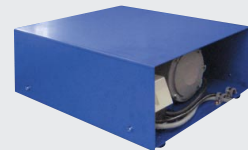

H : 3 Phase Unit  
W360X L430X H176mm



I : 3 Phase Unit  
W459X L555X H184mm

Model	Maximum Capacity (kg)	Lifting Height (mm)	Table Dimensions (mm)				Motor (kw)	Lifting Speed (sec)		Weight (kg)	Hydraulic Unit	Cable (m)		High Pressure Hose (m)
			Width	Length	Minimum Height	Maximum Height		50Hz	60Hz			Power Source	Operating SW	
<b>3 Phase 200V</b>														
LX25SA-B	250	470	518	810	59	529	0.375	13	11	98	G	5.3	3.5	1.55
LX25LA-B		700		1,010	60	759		18	15	116				
LX50SA-B		470		810	60	530		22	19	104				
LX50LA-B	500	700	520	1,010	760	0.75	33	28	123	H	5	3	2.5	
LX100N-B	1,000	900	780	1,280	976		25	21	194					
LX100W-B							215							
LX200N-B						343								
LX200W-B	2,000	1,000	1,000	1,500	95	1.5	29	24	423	I	5.3	3.5	2.4	
LX200WL-B	2,000	450												
LX300N-B	3,000	861	732	1,350	995				417					
LX300WM-B	1,500	493	1,000	1,500	134	1.5	31	26	525	I	4.7	2.6	2.4	
LX300WL-B	2,000	2.15												
<b>Single Phase 100 V</b>														
LX25SB-B	250	470	518	810	59	529	0.4	11	9	93	G	5.3	3.5	1.55
LX25LB-B		700		1,010	60	759		16	13	111				
LX50SB-B		470		810	60	530		21	18	105				
LX50LB-B	500	700	520	1,010	760	0.4	31	26	124	G	5.3	3.5	1.55	



# Heavy Duty Lift Tables

The Simple Solution to Lifting Heavy Loads to a Comfortable Working Height

**NX Series** Capacity **1000kg**



X10410-B

Separate

Width×Length×Height =  
360×430×176 (mm)



High Pressure  
Hose 3m



NX100WC-B

1 Stage Type

Internal



2X11214-B

2 Stage Type

1 Stage Type																	
Model	Maximum Capacity (kg)	Lifting Height (mm)	Table Dimensions (mm)				Motor (kw)	Lifting Speed (sec)		Weight (kg)	Hydraulic Unit	Cable (m)		High Pressure Hose (m)			
			Width	Length	Minimum Height	Maximum Height		50Hz	60Hz			Power Source	Operating SW				
X10410-B	1,000	600	400	1,000	155	755	0.75	13	11	163	Separate	5	3				
X10413-B		845		1,340	1,000	24		20	210								
X10415-B		950		1,500	205	1,155		24	20	248							
NX100NA-B		400	640	850	155	555	0.75	10	8	166	Internal	4.3	3				
NX100NB-B		600		1,000		755		13	11	180							
NX100NC-B		845		1,340		1,000		24	20	230							
NX100ND-B		950		1,500		205		1,155	17	14				253			
NX100NE-B		1,305		1,800	205	1,510	25	21	318								
NX100WA-B		400		780	850	155	555	0.75	10	8				185	Internal	4.3	-
NX100WB-B		600			1,000		755		13	11				199			
NX100WC-B		845			1,340		1,000		24	20				249			
NX100WD-B		950	1,500		205		1,155		17	14	274						
NX100WE-B		1,305	1,800		205	1,510	25	21	340								
NX100WCY-B		845	1,000		1,340	155	1,000	0.75	24	20	264	Internal	4.9	-			
NX100WDY-B		950			1,500	205	1,155		17	14	286						
NX100WEY-B		1,305			2,000	205	1,510		25	21	362						
X11224-B	1,305	1,200		2,400	207	1,512	25		21	505							

2 Stage Type														
Model	Maximum Capacity (kg)	Lifting Height (mm)	Table Dimensions (mm)				Motor (kw)	Lifting Speed (sec)		Weight (kg)	Hydraulic Unit	Cable (m)		High Pressure Hose (m)
			Width	Length	Minimum Height	Maximum Height		50Hz	60Hz			Power Source	Operating SW	
2X10607-B	1,000	900	600	780	255	1,155	0.75	33	28	231	Internal	4.8	3	
2X10610-B		1,250		1,000		1,505		45	38	255				
2X10910-B		1,400	850	1,150		1,655	1.13	24	20	335				
2X10611-B			600					322						
2X10911-B		850	365											
2X11211-B		1,200	385											
2X10614-B		1,800	600	1,400		306	2,106	1.13	34	28				375
2X10914-B			850											405
2X11214-B			1,200		600									
2X10618-B			600		605									
2X10918-B		2,400	850	1,850	356	2,756	1.5	49	41	726				
2X11218-B			1,200							827				

Regarding Specifications (see pages 25, 26)

( N ) X ○ ○ - B

※Push buttons are standard



**NX Series**

Capacity **2000~3000kg**



X21015-B

Model	Maximum Capacity (kg)	Lifting Height (mm)	Table Dimensions (mm)				Motor (kw)	Lifting Speed (sec)		Weight (kg)	Hydraulic Unit	Cable (m)		High Pressure Hose (m)				
			Width	Length	Minimum Height	Maximum Height		50Hz	60Hz			Power Source	Operating SW					
X20713-B	2,000	800	700	1,300	200	1,000	1.5	18	15	340	Internal	4.7	3					
X21013-B			1,000							388								
X20715-B		700	1,500	215	1,215	23		19	378									
X21015-B		1,000	428															
X21020-B		1,000	2,000	250	1,500	30		25	515									
X21224-B		1,250	1,200	2,400	252				1,502	620								
X30713-B		3,000	800	700	1,300	235		1,035	1.5	22				19	383	Internal	4.7	3
X31013-B				1,000											435			
X30715-B			700	1,500	245	1,245		30		25				421				
X31015-B			1,000	482														
X31020-B	1,250		2,000	280	1,530	38	31	573										
X31224-B	1,200		2,400	280	1,530			670										

EL100-F (Rotating platform comes standard)



Movable Skid Type

A rotating platform is attached to the top of the table.



Mawaru Rotating Platform



Foot Switch

※Can also be attached to other models.

Model	Maximum Capacity (kg)	Lifting Height (mm)	Table Dimensions (mm)				Motor (kw)	Lifting Speed (sec)		Weight (kg)	Hydraulic Unit	Cable (m)		High Pressure Hose (m)
			Width	Length	Minimum Height	Maximum Height		50Hz	60Hz			Power Source	Operating SW	
EL100-F	1,000	600	1,015	1,015	326	926	0.75	13	11	317	Internal	4.3	3	-



# Heavy Duty Lift Tables

The Simple Solution to Lifting Heavy Loads to a Comfortable Working Height

**AX Series** Capacity 1000~3000kg

## 1 Stage Type



AX100RG-B

## 2 Stage Type



2AX100BS-B

## 3 Stage Type

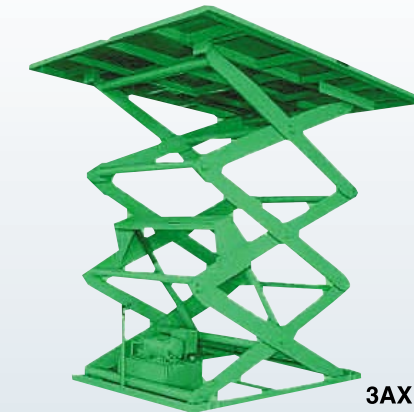

3AX100FT-B

Hydraulic Unit is separate

- J : 450×500×310
- K : 500×600×350
- L : 600×700×350
- M : 600×700×450
- N : 700×800×450

※Unit height is height including cover.

## Regarding Specifications (see pages 27, 28)

AX ○ ○ - B



※Push buttons are standard

1 Stage Type																	
1000kg Capacity																	
Model	Maximum Capacity (kg)	Lifting Height (mm)	Table Dimensions (mm)				Motor (kw)	Lifting Speed (sec)		Weight (kg)	Hydraulic Unit	Cable (m)		High Pressure Hose (m)			
			Width	Length	Minimum Height	Maximum Height		50Hz	60Hz			Power Source	Operating SW				
AX100RF-B	500	1,000	1,000	770	270	0.7	Internal	3	5	-	3	5	-				
AX100RG-B	800	1,340	1,070	13										11	281		
AX100RH-B	900	1,250	1,500	21										18	327		
AX100SH-B				26										22	367		
AX100RI-B	1,080	1,250	1,800	30										25	448		
AX100SI-B				35										29	426		
AX100VJ-B				40										33	513		
AX100XJ-B	1,200	900	2,000	46										38	417		
AX100YJ-B				1.5										25	20	48	542
AX100ZJ-B																578	

2 Stage Type																		
1000kg Capacity																		
Model	Maximum Capacity (kg)	Lifting Height (mm)	Table Dimensions (mm)				Motor (kw)	Lifting Speed (sec)		Weight (kg)	Hydraulic Unit	Cable (m)		High Pressure Hose (m)				
			Width	Length	Minimum Height	Maximum Height		50Hz	60Hz			Power Source	Operating SW					
2AX100AP-B	1,000	960	600	800	254	1,214	1.5	3	5	-	J	3	5					
2AX100AR-B														14	11	219		
2AX100BR-B		1,140	900	950										1,394	21	17	259	
2AX100AS-B															22	18	332	
2AX100BS-B		1,380	900	1,150										1,634	27	23	314	
2AX100BT-B															31	25	384	
2AX100CT-B		1,650	1,200	1,380										1,904	35	29	465	
2AX100DV-B															573			
2AX100EV-B		2,000	900	1,670										2,254	2.2	45	37	534
2AX100CV-B																		597
2AX100CW-B	2,400	1,200	2,000	350	2,750	60	50	825										

2000kg Capacity																		
2AX200GP-B	2,000	960	650	800	330	1,290	1.5	3	5	-	K	3	5					
2AX200GR-B														23	19	300		
2AX200HR-B		1,140	900	950										1,470	28	23	360	
2AX200GS-B															38	32	470	
2AX200HS-B		1,380	900	1,150										1,710	41	34	510	
2AX200HT-B															43	35	620	
2AX200IT-B		1,650	1,200	1,380										1,980	2.2	58	49	680
2AX200IV-B																		870
2AX200HV-B		2,000	900	1,670										350	2,350	77	64	930
2AX200IW-B																		1,100
2AX200IW-B	2,400	900	2,000	380	2,780	77	64	1,170										

3000kg Capacity																
2AX300JS-B	3,000	1,380	900	1,150	400	1,780	2.2	3	5	3	L	3	5			
2AX300JT-B														36	30	650
2AX300KT-B		1,650	1,200	1,380	420	2,070								44	37	780
2AX300JV-B														820		
2AX300KV-B		2,000	900	1,670	450	2,450								64	53	1,000
2AX300JW-B																1,100
2AX300KW-B	2,400	900	2,000	500	2,900	82	68	1,330								

3 Stage Type																		
1000kg Capacity																		
Model	Maximum Capacity (kg)	Lifting Height (mm)	Table Dimensions (mm)				Motor (kw)	Lifting Speed (sec)		Weight (kg)	Hydraulic Unit	Cable (m)		High Pressure Hose (m)				
			Width	Length	Minimum Height	Maximum Height		50Hz	60Hz			Power Source	Operating SW					
3AX100DP-B	1,000	1,400	600	800	400	1,800	1.5	3	5	-	K	3	5					
3AX100DR-B														32	27	310		
3AX100ER-B		1,700	900	950										2,100	25	21	330	
3AX100DS-B															29	24	370	
3AX100ES-B		2,050	600	1,150										2,450	2.2	38	31	430
3AX100ET-B																		40
3AX100FT-B		2,500	900	1,380										2,900	52	43	630	
3AX100FT-B																		680



# Electric Screw Drive Type Lift

The heavy duty series for electric type lifts.  
Stop at just the right height, and operate quietly.

Capacity 600~2000kg



XS061010-B

- ① Made to minimize horizontal sway, work can be carried out safely.
- ② A single speed while lifting and lowering, increasing efficiency.
- ③ Even if left alone for a long time, the table will not naturally lower when raised.
- ④ Excellent stopping precision.
- ⑤ Maintenance is simple.
- ⑥ No oil spills, helping maintain a clean work environment.
- ⑦ Quiet while lifting.

600kg Capacity																
Model	Maximum Capacity (kg)	Lifting Height (mm)	Table Dimensions (mm)				Motor (kw)	Lifting Speed (sec)				Weight (kg)	Cable (m)			
			Width	Length	Minimum Height	Maximum Height		50Hz	60Hz	50Hz	60Hz		Power Source	Operating SW		
XS060610-B	600	450	640	1,000	185	635	0.4	15	13	15	13	260	3	5		
XS060810-B			800													
XS061010-B			1,000													
XS060612-B			640												1,200	835
XS060812-B			800													
XS061012-B			1,000													
XS061212-B		1,200														
XS060615-B		800	1,500	210	1,010											
XS060815-B						800										
XS061015-B						1,000										
XS061215-B		1,200														
XS060618-B		1,000	1,800	210	1,210	0.4	37	31	37	31	31	395	3	5		
XS060818-B															640	
XS061018-B															800	
XS061218-B															1,000	
XS061218-B															1,200	
XS061218-B															1,200	
1200kg Capacity																
XS120810-B	1,200	450	800	1,000	230	680	0.75	15	12	15	12	355	3	5		
XS121010-B			1,000													
XS120812-B			800													
XS121012-B			1,000												1,200	880
XS121212-B			1,200													
XS120815-B			800													
XS121015-B		1,000	1,500	1,030												
XS121215-B		1,200														
XS120818-B		800														
XS121018-B		1,000	1,800	1,230												
XS121218-B		1,000														
XS121218-B		1,200														
2000kg Capacity																
XS201012-B		2,000	650	1,000	1,200	280	930	1.5	20	17	20	17	545	3	5	
XS201212-B				1,200												
XS201015-B				1,000												
XS201215-B			1,200	1,500	1,080											
XS201018-B			1,000													
XS201218-B	1,200		1,800			300	1,300									
XS201018-B	1,000															
XS201218-B	1,200															

# Vario Screw Lift

With Teaching Function

A lift with a mind added in. Quiet, accurate and clean.

Capacity 100~300kg



Push Button SW



XS020506-B

1 Stage Type



2XS010508-B

2 Stage Type



XS0150508J-B

Accordion Attached

## Lift With Teaching Functions Included

The lift stop station can be registered, and made to stop in the same place again.

### Simple Registration!

Up to 14 stops can be registered in order to meet customer needs

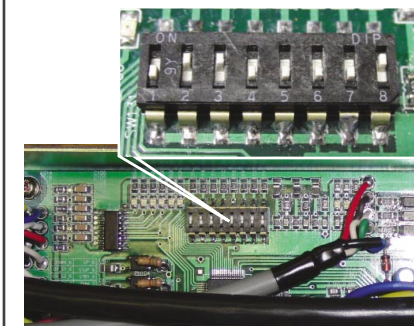

### SW No.1

Lift movements can be set up easily.

#### Automatic Retention

Once the switch is pressed, the lift will automatically move to the set position and stop.

#### Inching

Moves as long as the switch is pressed.

### SW No.4·5

Can automatically stop at a specific height.

#### With or Without Intervening Stops

Push the switch and match it to the height you want it to stop at to register. It will automatically stop at this height next time.

### SW No.2·3

Speed can be set up.

#### Standard Speed or Half Speed

Lifting and lowering speeds can be set separately according to the operation takt.

### Option (separate charge)



Foot switch for simple operation.

The standard 3 inputs and 5 outputs setup can be customized. Outputs indicate the lifter operation state but 3 of them are customizable to necessary outputs.

1 Stage Type														
Model	Maximum Capacity (kg)	Lifting Height (mm)	Table Dimensions (mm)				Motor (w)	Lifting Speed (sec)	Maximum Specifications Frequency (Number/ Time)	Weight (kg)	Cable (m)			
			Width	Length	Minimum Height	Maximum Height					Power Source	Operating SW		
XS010506-B	100	400	500	650	130	530	67	10	53	55	5.8	3.95		
XS0150508-B													540	813
XS010512-B		800											1,200	950
XS020506-B		400											650	550
XS020508-B		540											813	690
XS020512-B		800											1,200	970
XS030508-B	300	540	813	150	690	27	15	64	5.4	3.55				
Accordion Attached														
XS010506J-B	100	400	600	780	130	530	67	10	42	66	5.8	3.95		
XS0150508J-B													540	945
XS010512J-B		800											1,330	950
XS020506J-B		400											780	550
XS020508J-B		540											945	690
XS020512J-B		800											1,330	970
XS030508J-B	300	540	945	150	690	27	12	80	5.4	3.55				
2 Stage Type														
Model	Maximum Capacity (kg)	Lifting Height (mm)	Table Dimensions (mm)				Motor (w)	Lifting Speed (sec)	Maximum Specifications Frequency (Number/ Time)	Weight (kg)	Cable (m)			
			Width	Length	Minimum Height	Maximum Height					Power Source	Operating SW		
2XS010508-B	100	850	500	813	220	1,070	67	22	20	82	5.3	3.45		
2XS010510-B		1,000	518	1,010	235	1,235		25	17	113	5.75	3.9		
Accordion Attached														
2XS010508J-B	100	850	600	945	220	1,070	67	22	16	100	5.3	3.45		
2XS010510J-B		1,000	650	1,140	235	1,235		25	13	131	5.75	3.9		



# REMODELING EXAMPLE

Don't you want to make your job easier?  
Bishamon products can be customized to fit the needs of your workplace.



## Hand Pallet Trucks

**Fork Extensions** (possible capacity reduction)



**Roll Receiver**



**Stainless Steel Fork Covers**



**Fork Width** (possible capacity reduction)  
Expand [up to 1000mm] Reduce [up to 400mm]

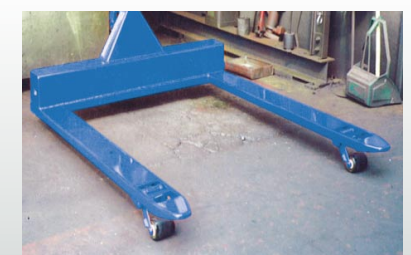

**Cut Forks**



**Raised Forks**



**Wheel Covers**

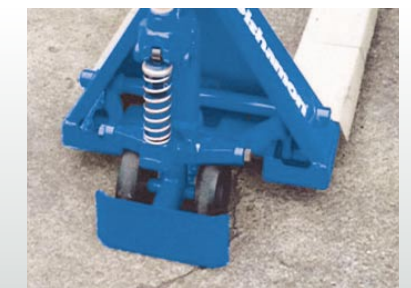

**Iron Handle**



**Lowering Adjustment Dial**



**Minor Water Resistance**



**Additional Wheels**



## Hydraulic Stackers Series



**Support Arm Guides**

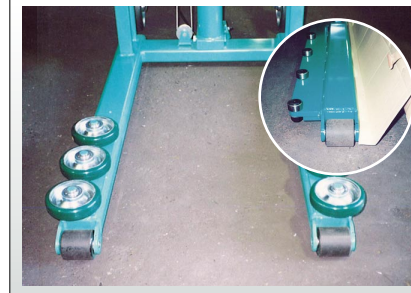

**Conveyor Attachment (with Pipe Stoppers)**

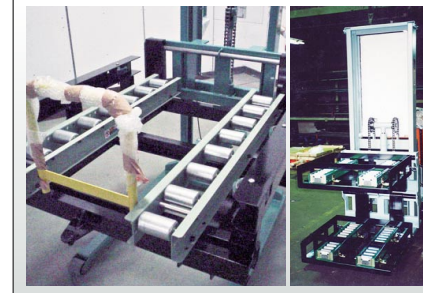

**Fork (Legs) Width Extension [up to 1500mm]**



**Stainless Steel Fork (Covers)**



**Complete Acrylic Cover for Operating Side**

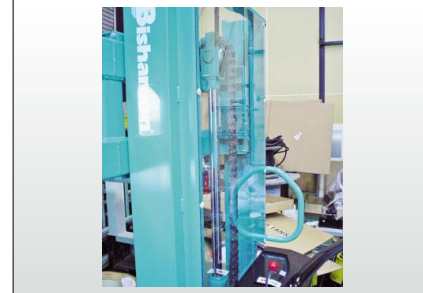

**Sprocket Covers**



**Push Button Switch Type**



**Limit Switch Attachment**

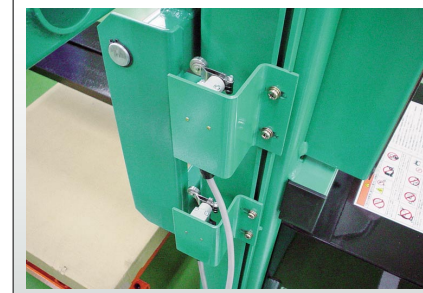

**Hanging Hook Attachment**



**Steering Wheel Cover**

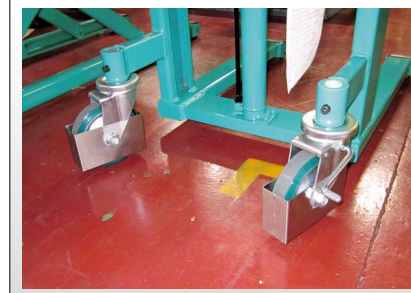

**Ram Fork**



**Solid Wood Fork (MIN Down)**

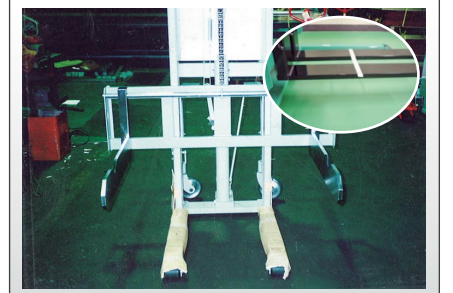

**Change Front Wheels**



**Change Power Voltage**

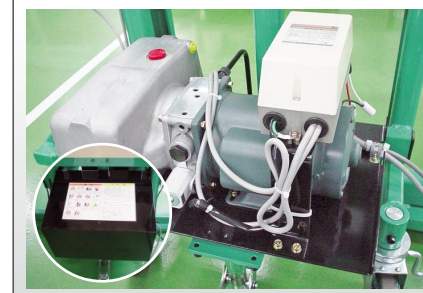

**Upside-Down Fork [up to min 500mm]**

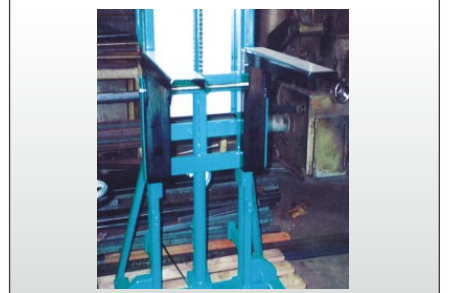



## Skid Lifter



Steering Wheel Cover (Foot Protection)



Conveyor Attachment



Removable Table Attachment



Remote Control Type (Push Buttons/ Foot Switch)



Raised Forks



Increased Lifter Height (Change Wheels)

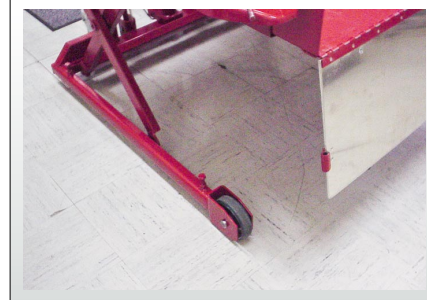

Rotating Lamp Attachment



Limit Switch Attachment

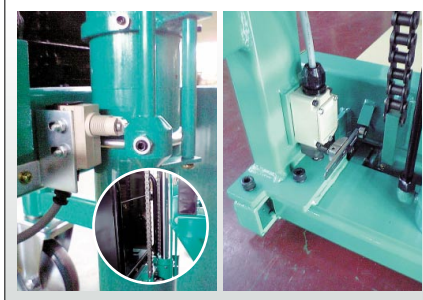

## Platform Stacker

Roll Receiver Forks, Table



Nylon Wheels



Tip Angle Attachment

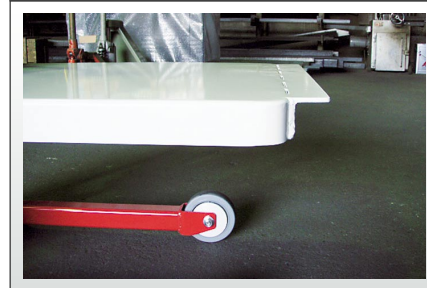

Adjustable 4 Wheels



## Mobile Lift Table



Stainless Steel Table (Cover)



Change to No Handle & Foot Pedal Lowering Lever (Removable)



Accordion Attachment



Raised Table [up to 50mm]



Fixed Front Wheels, Adjustable Switching Caster Wheels



Raised Wheels

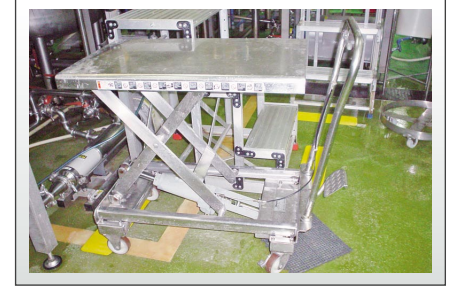

Roll Receiver

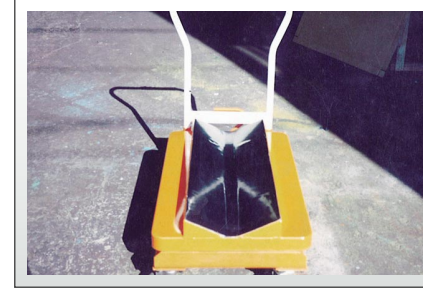

Conveyor Attachment



Lower Down Parts

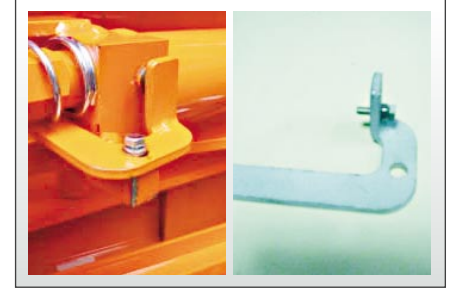

## Mobile Work Positioner



Stationary



Stainless Steel Table, Handle



## Tilt Truck

Bucket Stainless



High Looper Attachment Kit





# Table Lift

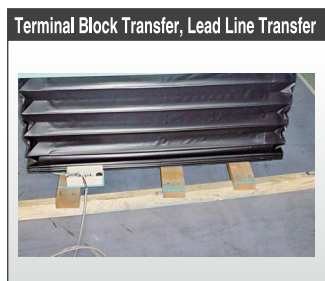
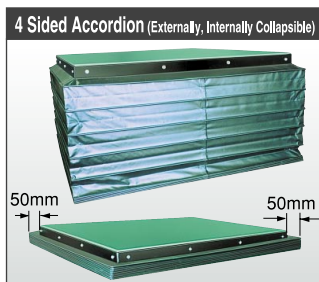
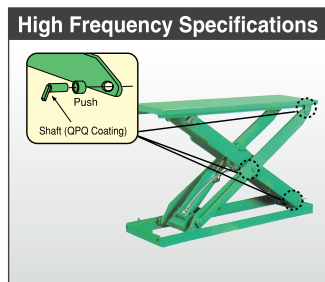
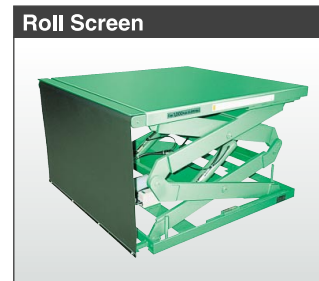
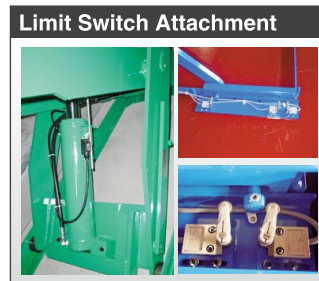
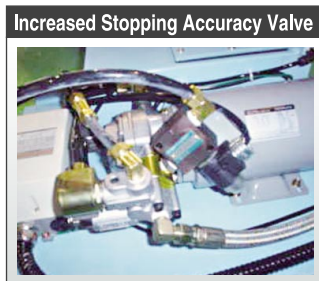
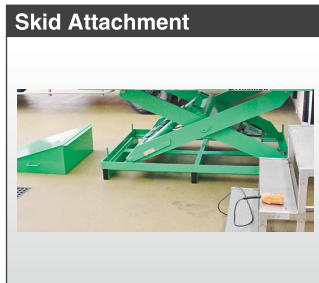

Improved Category	
Lifting Speed Up (3 Phase 200V)	2 Times
Lifting Speed Up	1.5 Times

Improved Category		Notes
Change Control Voltage	Lowering 100V	No operating switch or magnet, lead line 1,000mm out (motor, lowering solenoid)
Extend Lead Line	Lowering 24V	
Change Control Voltage	Lowering 100V	No operating switch or magnet, terminal block attached (motor, lowering solenoid)
Attach Terminal Block	Lowering 24V	
Change Control Voltage	Lowering 100V	Operating switch attached (with transformer)
with Operating Switch	Lowering 24V	

# Hand Pallet Trucks STAINLESS

Perfect for transporting pallets or equipment in clean areas.

## All Stainless Type

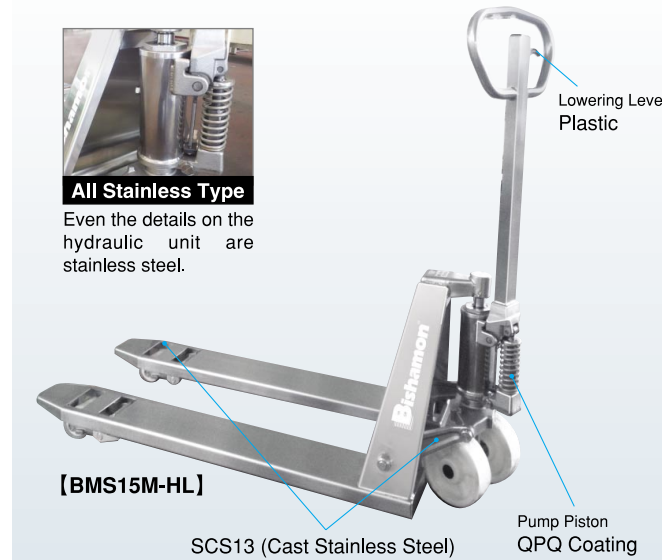

**All Stainless Type**  
Even the details on the hydraulic unit are stainless steel.

## Partial Stainless Type

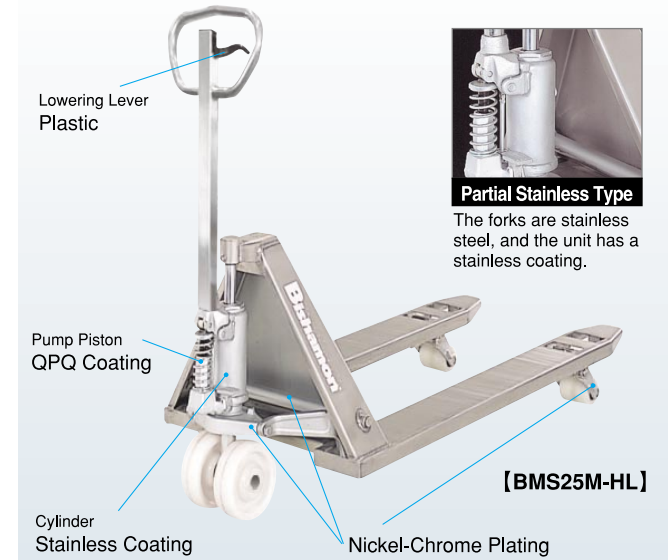

**Partial Stainless Type**  
The forks are stainless steel, and the unit has a stainless coating.

※QPQ Coating: Coating with excellent abrasion and corrosion resistance.

## Jobs Involving Water



## Jobs in Clean Rooms

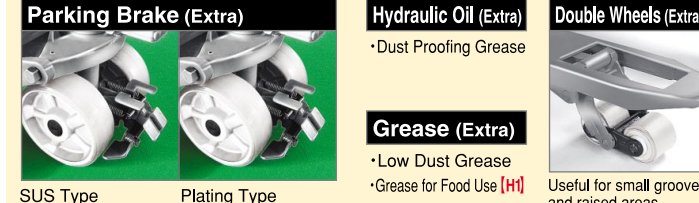
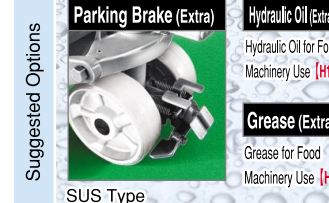

**Main Body Materials**  
SUS 304 (Standard)  
※Ask for SUS 316.

**Surface Finish Choose!**  
Hairline Finish (HL)  
Hairline Standard (Standard)  
Mirror Finish (PK)  
#400 Mirror (Extra)

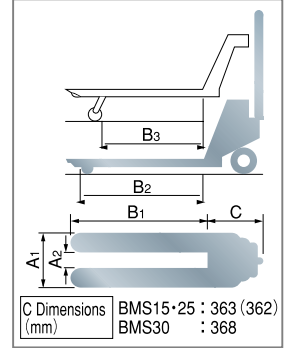

Model	Maximum Capacity (kg)	Fork (mm)					Wheels (Nylon)		Weight (kg)						
		External Width	Length			Internal Width	Diameter × Width (mm)								
		A <sub>1</sub>	B <sub>1</sub>	B <sub>2</sub>	B <sub>3</sub>	A <sub>2</sub>	Front Wheel	Support Wheels							
<b>All Stainless Type - Manually Operated Type</b>															
<b>Standard</b> [Fork Height] 80~200mm	BMS15SS-HL	1,500	520	810	674	537	214	80×100	175×63	72					
	BMS15S-HL			980	844	707				75					
	BMS15M-HL			1,070	934	794				79					
	BMS15L-HL			1,150	1,014	874				82					
	BMS15LL-HL			1,220	1,084	944				88					
<b>Thin Type</b> [Fork Height] 65~165mm	BMS15SS-L65-HL	1,500	520	810	672	554	214	65×100	175×63	68					
	BMS15S-L65-HL			980	842	724				71					
	BMS15M-L65-HL			1,070	932	813				75					
	BMS15LL-L65-HL			1,220	1,082	963				83					
<b>Partial Stainless Type - Manually Operated Type</b>															
<b>Standard</b> [Fork Height] 80~200mm	BMS25S-HL	2,500	520	980	844	706	214	80×100	175×63	85					
	BMS25M-HL			1,070	934	793				89					
	BMS25L-HL			1,150	1,014	874				92					
	BMS25LL-HL			1,220	1,084	944				99					
	BMS30S-HL			3,000	520	980				912	669	214	Standard Double Wheels 80×71	175×63	86
	BMS30M-HL					1,070				1,002	759				90
	BMS30L-HL					1,150				1,082	839				93
BMS30LL-HL	1,220	1,151	910	379	110										



# Hydraulic Stackers **STAINLESS**

Perfect for stacking on shelves and bringing work to high locations in clean areas

## Manually Operated Models

Capacity 150~500kg

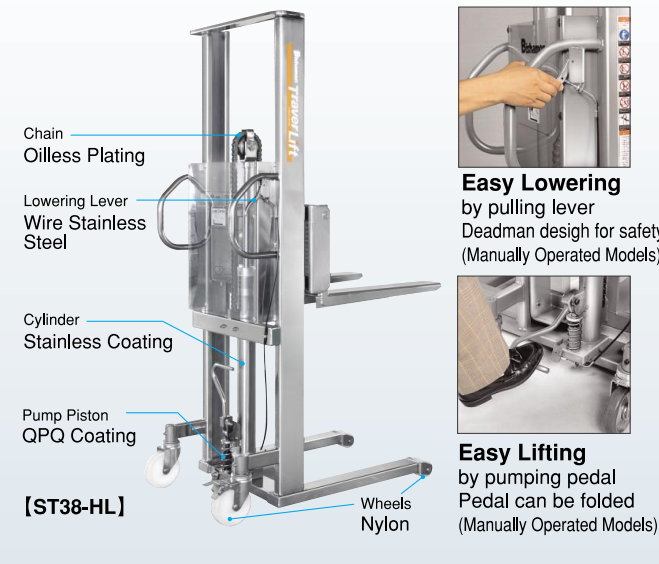

**Easy Lowering**  
by pulling lever  
Deadman design for safety  
(Manually Operated Models)



**Easy Lifting**  
by pumping pedal  
Pedal can be folded  
(Manually Operated Models)

## Battery Powered Models

Capacity 380~500kg

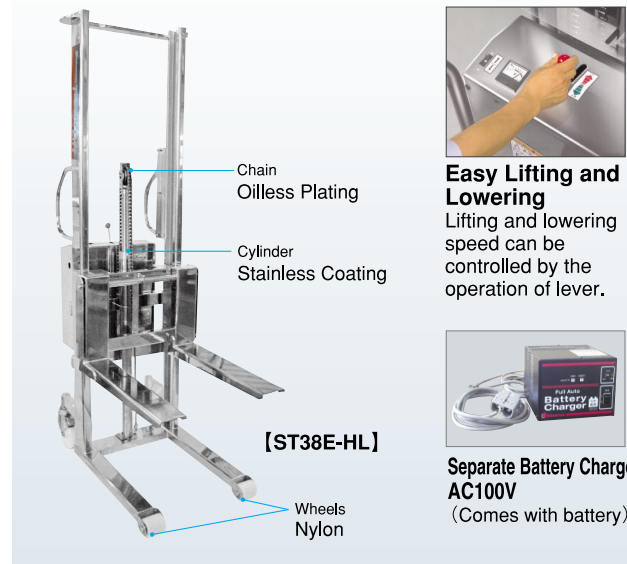

**Easy Lifting and Lowering**  
Lifting and lowering speed can be controlled by the operation of lever.

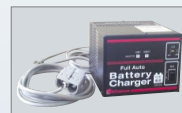

**Separate Battery Charger/AC100V**  
(Comes with battery)

※QPQ Coating: Coating with excellent abrasion and corrosion resistance.

### Main Body Materials

- SUS 304 [Standard]
- ※ Ask for SUS 316.

### Surface Finish Choose!

- Hairline Finish [HL]  
Hairline Standard [Standard]
- Mirror Finish [PK]  
#400 Mirror [Extra]

### Manually Operated Models

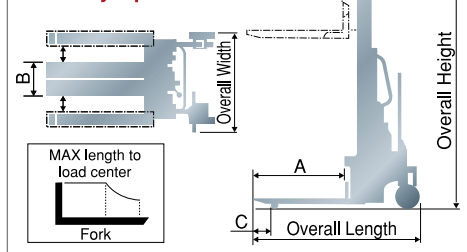

### Battery Powered Models

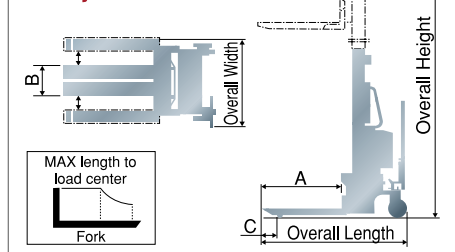

Model	Maximum Capacity (kg)	Fork (mm)			Arm (mm)			Total Height (mm)	Total Width (mm)	Total Length (mm)	Wheels (Urethane)		Weight (kg)	
		Length A	Slide External Width B	Extended Width C	External Width	Internal Width	Gap with Floor				Diameter×Width (mm)	Front Wheels		Support Wheels
<b>Manually Operated Type</b>														
Lifting Height 750 [Fork Height] 90~840mm	<b>STS15-HL</b>	150	750	125~628	277	502	360	26	1,233	659	1,198	80×32	100×32	57
	<b>STS38-HL</b>	380	800	232~600	234	586	394	31	1,261	683	1,306	70×73	150×42	135
Lifting Height 1200 [Fork Height] 90~1290mm	<b>STL25-HL</b>	250	550	125~628	77	500	360	26	1,592	659	998	80×32	100×32	62
	<b>STL38-HL</b>	380	600	232~558	119	544	352	31	1,666	641	1,099	70×73	150×42	117
	<b>STL50-HL</b>	500	600	232~600	34	586	394	31	1,669	683	1,106	70×73	150×42	151
Lifting Height 1500 [Fork Height] 90~1590mm	<b>ST25-HL</b>	250	550	125~628	77	500	360	26	1,892	659	998	80×32	100×32	67
	<b>ST38-HL</b>	380	600	232~558	119	544	352	31	1,966	641	1,099	70×73	150×42	122
	<b>ST50-HL</b>	500	600	232~600	34	586	394	31	1,969	683	1,106	70×73	150×42	156
<b>Wide</b>	<b>ST20WW-HL</b>	200	1,000	232~558	319	1,375	1,175	31	1,966	1,375	1,499	70×73	150×42	159
	<b>ST30WW-HL</b>	300	1,000	232~600	234	1,375	1,175	31	1,969	1,375	1,507	70×73	150×42	193

Model	Maximum Capacity (kg)	Fork (mm)			Arm (mm)			Total Height (mm)	Total Width (mm)	Total Length (mm)	Battery Capacity	Lifting Time (sec)	Wheels (Urethane)		Weight (kg)	
		Length A	Slide External Width B	Extended Width C	External Width	Internal Width	Gap with Floor						Diameter×Width (mm)	Front Wheels		Support Wheels
<b>Battery Powered Raising/ Lowering Type</b>																
Lifting Height 1200 [Fork Height] 90~1290mm	<b>STL38E-HL</b>	380	600	232~558	119	544	352	31	1,666	641	1,075	12V36Ah/5Hr	16	70×73	150×42	151
	<b>STL50E-HL</b>	500	600	232~600	34	586	394	31	1,669	683	1,085	12V64Ah/5Hr	18	70×73	150×42	187
Lifting Height 1500 [Fork Height] 90~1590mm	<b>ST38E-HL</b>	380	600	232~558	119	544	352	31	1,966	641	1,075	12V36Ah/5Hr	20	70×73	150×42	156
	<b>ST50E-HL</b>	500	600	232~600	34	586	394	31	1,969	683	1,085	12V64Ah/5Hr	22	70×73	150×42	192
<b>Wide</b>	<b>ST50EWN-HL</b>	500	600	232~600	34	871	679	31	1,969	875	1,085	12V64Ah/5Hr	22	70×73	150×42	202

※Not water resistant. Please ask before getting wet. ※Please ask about screw-operated types.

# Skid Lifter **STAINLESS**

Capacity 500kg

Perfect for stacking on shelves and bringing work to high locations in clean areas

## Manually Operated Models

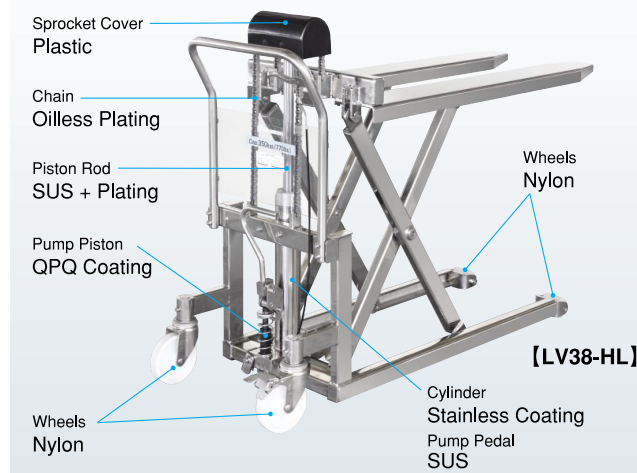

※QPQ Coating: Coating with excellent abrasion and corrosion resistance.

## Battery Powered Models

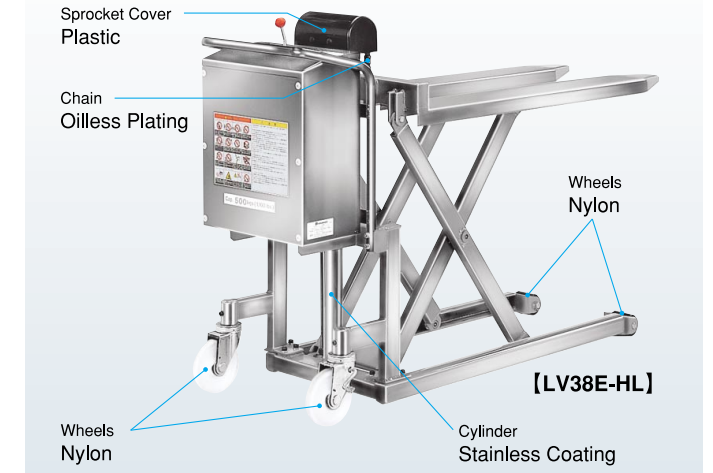

### Manually Operated Models

Model	Maximum Capacity (kg)	Fork (mm)					Total Width (mm)	Total Length (mm)	Pump Operation Count (Number of Times)	Wheels (mm)		Weight (kg)
		External Width A	Length B	Minimum Height C	Maximum Height D	Lifting Height E				Front Wheels	Support Wheels	
<b>Manually Operated Type (for Skid Pallets)</b> ※Single/Double-sided pallets cannot be used.												
<b>LV50NSS-HL</b>	500	460	810	83	613	530	543	1,302	28	70	150	87
<b>LV50SS-HL</b>		520			603	88						
<b>LV50N-HL</b>		460	833		750	543	1,573	39	100			
<b>LV50-HL</b>		520	833		750	603			101			
<b>LV50W-HL</b>		685	768		106							



The foot pump is a safe and compact collapsible type

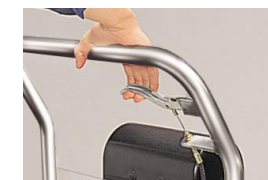

by pulling lever Deadman design for safety (All Models)

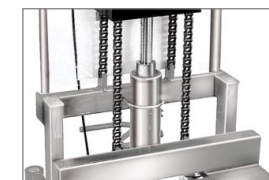

The Bishamon original hydraulic pump and cylinder are extremely reliable

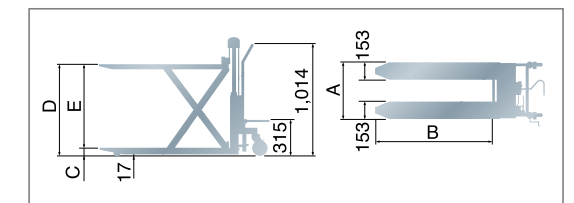

### Battery Powered Models

Model	Maximum Capacity (kg)	Fork (mm)					Total Width (mm)	Total Length (mm)	Lifting Time (S)	Lowering Time (S)	Battery	Wheels (mm)		Weight (kg)
		External Width A	Length B	Minimum Height C	Maximum Height D	Lifting Height E						Front Wheels	Support Wheels	
<b>Battery Powered Raising/ Lowering Type (for Skid Pallets)</b> ※Single/Double-sided pallets cannot be used.														
<b>LV50NSSE-HL</b>	500	460	810	83	603	520	555	1,300	7	Adjustable	12V/36Ah/5hr	70	150	122
<b>LV50SSE-HL</b>		520			603	123								
<b>LV50NE-HL</b>		460	833		750	555	1,570	10	135					
<b>LV50E-HL</b>		520	833		750	603			136					
<b>LV50WE-HL</b>		685	768		141									



**Easy Lifting and Lowering**  
Lifting and lowering speed can be controlled by the operation of lever.



**Separate Battery Charger AC100V**  
(Comes with battery)

### Option



**Battery Meter (Option)**  
Comes standard with electric drive types

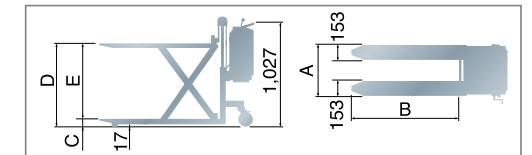

### Main Body Materials Surface Finish Choose!

- SUS 304 [Standard]
- ※ Ask for SUS 316.

- Hairline Finish [HL]  
Hairline Standard [Standard]
- Mirror Finish [PK]  
#400 Mirror [Extra]

# Platform Stacker **STAINLESS**

Handy and Easy Moving Platform Stacker

## Fork Models Manually Operated Models

Capacity 200~400kg

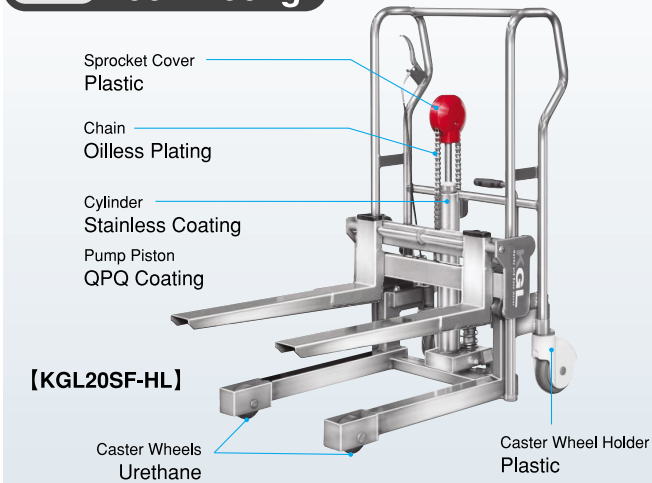

※ QPQ Coating: Coating with excellent abrasion and corrosion resistance.

## Table Models Manually Operated Models

Capacity 250~450kg

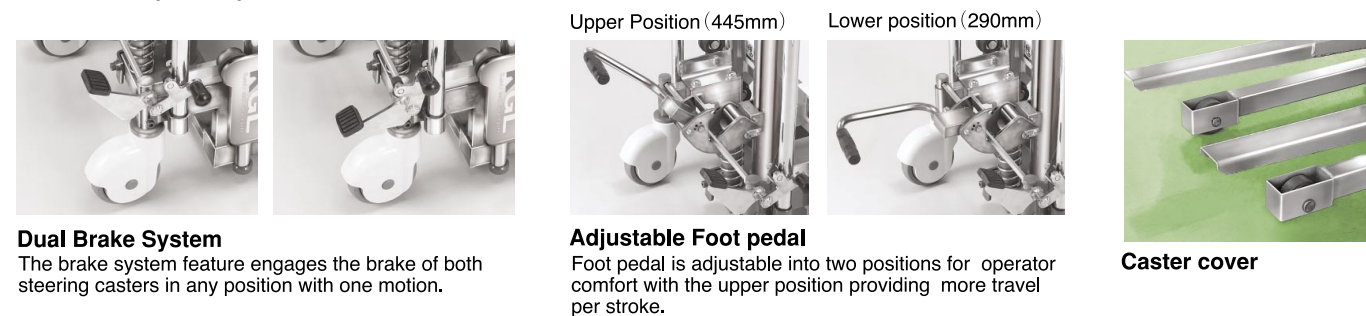
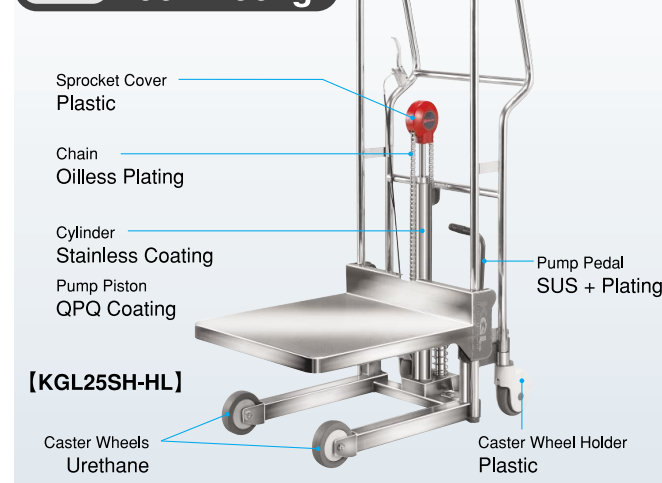

**Dual Brake System**  
The brake system feature engages the brake of both steering casters in any position with one motion.

**Adjustable Foot pedal**  
Foot pedal is adjustable into two positions for operator comfort with the upper position providing more travel per stroke.

**Caster cover**

**Adjustable Speed Improves Safety When Lowering/  
Simple Auto Fast Traverse Improves Efficiency**  
With no load (or a light load), lifting is twice as fast as when there is a load

## Fork Models [Manually Operated Models]

Model	Maximum Capacity (kg)	Fork			Arm External Width (mm)	Total Height (mm)	Total Width (mm)	Total Length (mm)	Pump Operation Count (Number of Times)	Wheels (mm)		Weight (kg)
		Height (mm)	Length (mm)	Slide External Width (mm)						Front	Rear	
<b>KGL20SF-HL</b>	200	95~	750	600	148~454	454	1,000	571	1,075	16 (9)	φ80	56
<b>KGL20SHF-HL</b>		95~1,120										
<b>KGL40SF-HL</b>	400	95~	750	600	232~495	495	1,020	625	1,133	27 (15)	φ70	84
<b>KGL40SHF-HL</b>		95~1,090										

Inside ( ) is for no load

## Table Models [Manually Operated Models]

Model	Maximum Capacity (kg)	Table		Arm External Width (mm)	Total Height (mm)	Total Width (mm)	Total Length (mm)	Pump Operation Count (Number of Times)	Wheels (mm)		Weight (kg)
		Height (mm)	Width×Length (mm)						Front	Rear	
<b>KGL25S-HL</b>	250	150~	540×600	480	1,000	568	1,033	16 (9)	φ125	φ125	55
<b>KGL25SH-HL</b>		150~1,170									
<b>KGL45S-HL</b>	450	150~	600×650	515	1,020	625	1,088	27 (15)	φ125	φ125	78
<b>KGL45SH-HL</b>		150~1,170									

Inside ( ) is for no load

# Mobile Lift Table **STAINLESS**

Perfect as a work table in clean areas or for delivery to and from conveyor belts.

Capacity 100~500kg

Surface Finish: Electrolytic Polishing

※ Ask if a 400 fine finish is preferred.

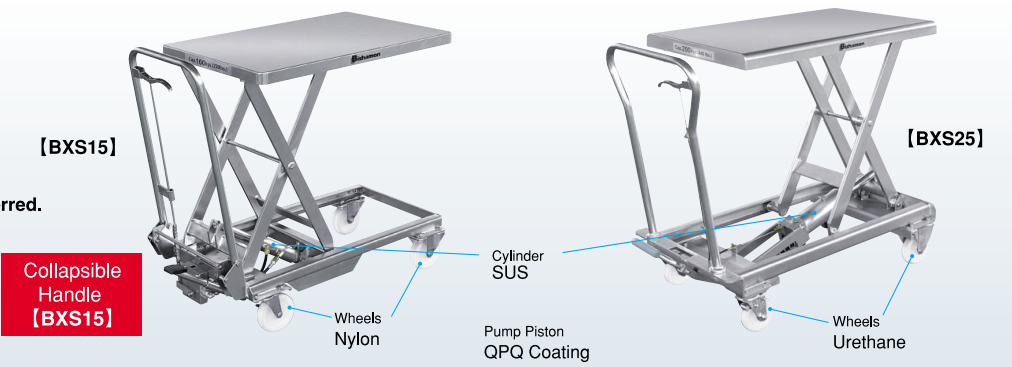

※QPQ Coating: Coating with excellent abrasion and corrosion resistance.

Model	Maximum Capacity (kg)	Table Dimensions Width×Length (mm)	Table Height (mm)	Total Height (mm)	Total Width (mm)	Total Length (mm)	Wheels		Adjustable Wheels	Pumping Count (Number of Times)	Weight (kg)
							Front (Fixed)	Rear (Adjustable)			
<b>Mobile Lift Table Manually Operated</b>											
Manual Lift Type	<b>BXS15</b>	150	450× 700	235~ 730	818	450	881	φ100 Nylon		17	35
	<b>BXS25</b>	250	500× 813	288~ 865	898	500	1,011	φ100 Nylon	Support Wheels	25	68
	<b>BXS30W</b>	300	518×1,010	433~1,578	960	520	1,273	φ150 Nylon		64	145
	<b>BXS50</b>	500		438~ 998						1,197	50

# Mobile Work Positioner **STAINLESS**

Perfect for stacking in clean areas.

Collapsed Capacity 50~600kg

Surface Finish: Electrolytic Polishing

※ Ask if a 400 fine finish is preferred.



Model	Adjustable Range (kg)	Table Dimensions Width×Length (mm)	Table Height (mm)	Total Height (mm)	Total Width (mm)	Total Length (mm)	Wheels		Adjustable Wheels	Weight (kg)
							Front (Fixed)	Rear (Adjustable)		
<b>Mobile Work Positioner</b>										
Automatic Lift Type	<b>ESXS05</b>	10~ 50	450× 700	262~659	798	450	836	φ100 Nylon		38
	<b>ESXS08</b>	20~ 80		262~650						
	<b>ESXS10</b>	30~100	262~659	898	500	998	φ100 Nylon	Support Wheels	63	
	<b>ESXS10L</b>	40~100	352~787							
	<b>ESXS21</b>	80~210	352~772	941	520	1,191	φ125 Nylon		104	
	<b>ESXS21L</b>	55~210	374~803							
	<b>ESXS40</b>	100~400	374~794	961	520	1,191	φ150 Nylon		115	
<b>ESXS60</b>	220~600	393~813								

# Tilt Truck **STAINLESS**

Capacity 150~250kg

Perfect for transporting ingredients in clean areas.



Model	Capacity (kgs)	Bucket			Total Height (mm)	Total Width (mm)	Total Length (mm)	Wheels		Weight (kg)
		Lip Height (mm)	Height (mm)	Capacity (m³)				Front (Fixed)	Rear (Adjustable)	
<b>DSS15T</b>	150	563	689	0.12	798	535	1,007	φ100Nylon		36
<b>DSS25T</b>	250	582	784	0.27	898	685	1,292	φ100Urethane		66



# Compact and Super Low Lift Tables

**STAINLESS**

**Main Body Materials** SUS 304 [Standard]  
 ※ Ask for SUS 316.

**Surface Finish Choose!**  
 Hairline Finish [HL] Hairline Standard [Standard]  
 Mirror Finish [PK] #400 Mirror [Extra]

## Compact Lift Tables

Capacity 300~500kg

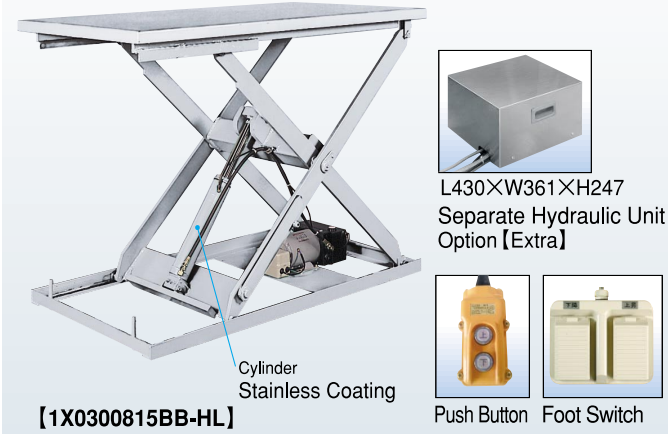

## Super Low Lift Tables

Capacity 250~1000kg

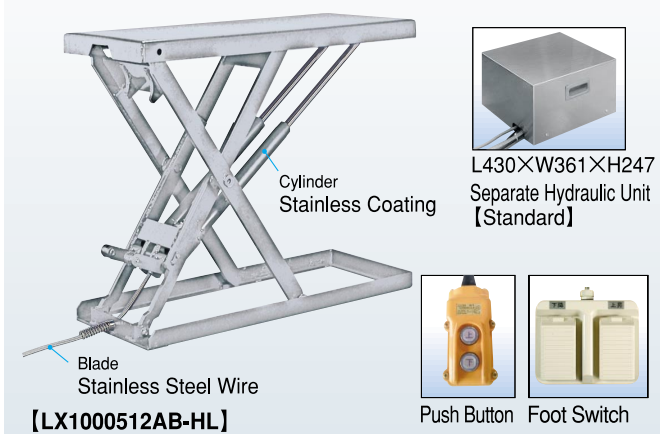

※QPQ Coating: Coating with excellent abrasion and corrosion resistance.

## Compact Lift Tables

Model	Maximum Capacity (kg)	Lifting Height (mm)	Table Dimensions (mm)		Motor (kw)	Lifting Speed (sec)		Weight (kg)	Hydraulic Unit	Cable (m)		High Pressure Hose (m)
			Width	Length		50Hz	60Hz			Power Source	Operating SW	
<b>Mini X Electric Operated Type</b>												
3 Phase 200V	1X0300612AB-HL	300	800	600	1,200	0.375	16	14	Internal	4.7	3	-
	1X0300812AB-HL			800								
	1X0300615AB-HL		1,000	600	1,500		20	17		186		
	1X0300815AB-HL			800								
	500	1X0500612AB-HL	800	600	1,200	0.375	28	24	Internal	4.7	3	-
		1X0500812AB-HL		800								
		1X0500615AB-HL	1,000	600	1,500		37	31		190		
		1X0500815AB-HL		800								
Single Phase 100V	1X0300612BB-HL	300	800	600	1,200	0.4	19	16	Internal	4.7	3	-
	1X0300812BB-HL			800								
	1X0300615BB-HL		1,000	600	1,500		25	21		181		
	1X0300815BB-HL			800								
	500	1X0500612BB-HL	800	600	1,200	0.4	31	26	Internal	4.7	3	-
		1X0500812BB-HL		800								
		1X0500615BB-HL	1,000	600	1,500		43	36		185		
		1X0500815BB-HL		800								

## Super Low Lift Tables

Model	Maximum Capacity (kg)	Lifting Height (mm)	Table Dimensions (mm)		Motor (kw)	Lifting Speed (sec)		Weight (kg)	Hydraulic Unit	Cable (m)		High Pressure Hose (m)
			Width	Length		50Hz	60Hz			Power Source	Operating SW	
<b>Super Low Lift Electric Operated Type</b>												
3 Phase 200V	LX0250508AB-HL	250	470	518	59	0.375	13	11	Separate	5.3	3.5	1.55
	LX0250510AB-HL			810								
	LX0500508AB-HL	500	470	518	60		22	19		104		
	LX0500510AB-HL			810								
	1,000	LX1000512AB-HL	900	518	76		0.75	25		21	194	
		LX1000712AB-HL			76							
Single Phase 100V	LX0250508BB-HL	250	470	518	59	0.4	11	9	Separate	5.3	3.5	1.55
	LX0250510BB-HL			810								
	LX0500508BB-HL	500	470	518	60		21	18		99		
	LX0500510BB-HL			810								
	700	LX0500508BB-HL	700	518	76		0.75	31		26	118	
		LX0500510BB-HL			76							

# Heavy Duty Lift Tables

Capacity 1000kg

**STAINLESS**

**Main Body Materials** SUS 304 [Standard]  
 ※ Ask for SUS 316.

**Surface Finish Choose!**  
 Hairline Finish [HL] Hairline Standard [Standard]  
 Mirror Finish [PK] #400 Mirror [Extra]

## NX Series

1 Stage Type



2 Stage Type

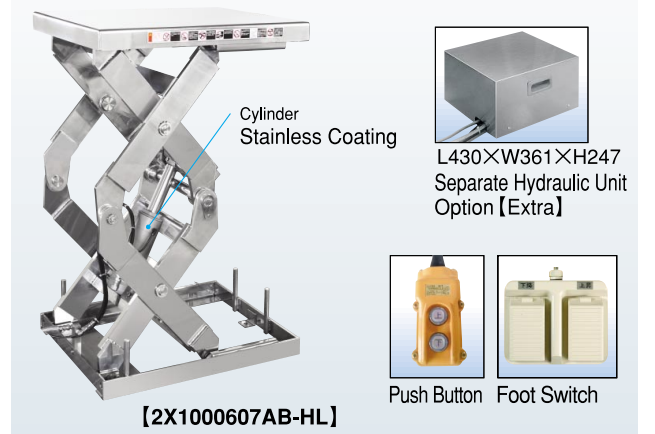

Model	Maximum Capacity (kg)	Lifting Height (mm)	Table Dimensions (mm)		Motor (kw)	Lifting Speed (sec)		Weight (kg)	Hydraulic Unit	Cable (m)		High Pressure Hose (m)	
			Width	Length		50Hz	60Hz			Power Source	Operating SW		
<b>1 Stage Type Electric Operated Type</b>													
3 Phase 200V	NX1000410AB-HL	1,000	600	1,000	755	0.75	13	11	Internal	4.7	3	-	
	NX1000413AB-HL												400
	NX1000415AB-HL		400	850	205		1,155	24		20	248		
	NX1000608AB-HL												850
	NX1000610AB-HL		600	1,000	155		755	13		11	180		
	NX1000613AB-HL												640
	NX1000615AB-HL		950	1,500	205		1,155	17		14	253		
	NX1000618AB-HL												1,305
	NX1000708AB-HL		400	850	155		755	10		8	185		
	NX1000710AB-HL												600
	NX1000713AB-HL		845	780	1,340		1,000	24		20	249		
	NX1000715AB-HL												950
	NX1000718AB-HL		1,305	1,800	205		1,510	25		21	340		
	NX1001013AB-HL												845
	NX1001015AB-HL		950	1,000	1,500		1,155	17		14	286		
	NX1001020AB-HL												1,305
NX1001224AB-HL	1,305	1,200	2,400	207	1,512	25	21	505					
<b>2 Stage Type Electric Operated Type</b>													
3 Phase 200V	2X1000607AB-HL	1,000	900	600	780	1.13	33	28	Internal	4.8	3	-	
	2X1000610AB-HL												1,250
	2X1000910AB-HL		1,400	850	1,150		1,655	28		23	365		
	2X1000611AB-HL												600
	2X1000911AB-HL		1,400	850	1,200		2,106	34		28	405		
	2X1001211AB-HL												600
	2X1000614AB-HL		1,800	850	1,400		306	66		55	605		
	2X1000914AB-HL												1,200
	2X1001214AB-HL		2,400	850	1,850		356	49		41	726		
	2X1000618AB-HL												600
	2X1000918AB-HL		1,200	850	1,850		356	1.5		49	41		827
	2X1001218AB-HL												



BISHAMON QUALITY! JAPAN QUALITY!

EC-MS1803②-1306-5000AT



**SUGIYASU CORPORATION**

3-21,4 Chome, Hongo Cho, Takahama City,  
Aichi Pref, Japan 444-1394  
Tel.+81-(0)566-53-1862 Fax.+81-(0)566-53-3722  
E-MAIL [sugiyasu@bishamon.co.jp](mailto:sugiyasu@bishamon.co.jp)  
<http://www.bishamon.co.jp/en/>

Distributed by